

4. Alternator Standard, 12V/55A

The alternator serves to keep the battery constantly charged. It is installed on the cylinder block by a bracket, and is driven from the V-pulley at the end of the crankshaft by a V-belt.

The type of alternator used in this engine is ideal for high speed engines with a wide range of engine speeds. It contains diodes that convert AC to DC, and an IC regulator that keep the generated voltage constant even when the engine speed changes.

4-1 Features

The alternator contains a regulator using an IC, and has the following features.

(1) The IC regulator is self-contained, and has no moving parts (mechanical contact points). It therefore has superior features such as freedom from vibration, no fluctuation of voltage during use, and no need for readjustment.

Also, it is of the over-heating compensation type and can automatically adjust the voltage to the most suitable level depending on the operating temperature.

(2) The regulator is integrated within the alternator to simplify external wiring.

(3) It is an alternator designed for compactness, lightness of weight, and high output.

(4) A newly developed U-shaped diode is used to provide increased reliability and easier checking and maintenance.

(5) As the alternator is to be installed on board, the following measures are taken to provide salt-proofing.

1) The front and rear covers are salt-proofed.

2) Salt-proof paint is applied to the diode.

3) The terminal, where the inboard harness is connected to the alternator, is nickel plated.

4-2 Specifications

Model of alternator	LR155-20 (HITACHI)
Model of IC regulator	TRIZ-63 (HITACHI)
Battery voltage	12V
Nominal output	12V/55A
Earth polarity	Negative earth (⊖)
Direction of rotation (viewed from pulley end)	Clockwise
Weight	4.3kg (9.5lb.)
Rated speed	5000 rpm
Operating speed	1000 ~ 9000
Speed for 13.5V	1000 or less
Output current at 20°C	over 53A/5000 rpm
Regulated voltage	14.5 ±0.3V (Standard temperature voltage gradient, -0.01/°C)

4-3 Characteristics

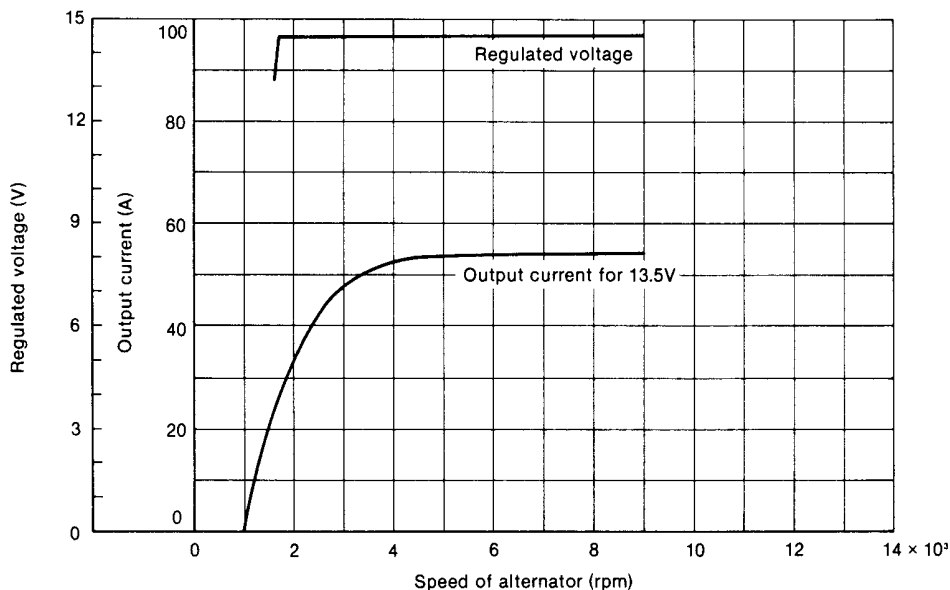

4-4 Construction

This is a standard rotating field type three-phase alternator. It consists of six major parts: the pulley, fan, front cover, rotor, stator and rear cover. The IC regulator is an integral part of the alternator.

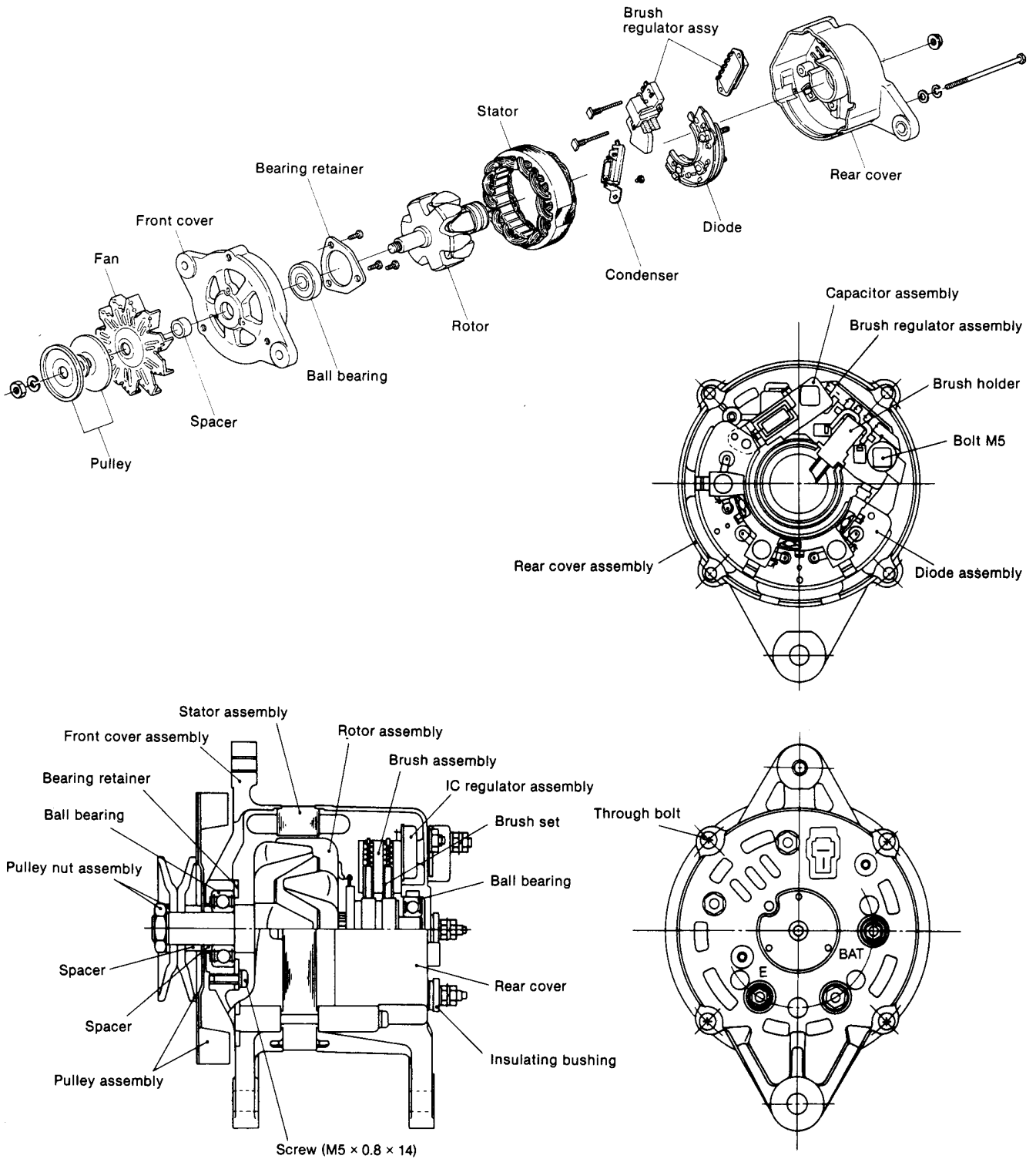

4-5 Alternator functioning

(1) IC regulator

The IC regulator is the transistor (Tr_1) which is series-connected with the rotor. The IC regulator controls the output voltage of the generator by breaking or conducting the rotor coil (exciting) current.

When the output voltage of the generator is within the standard value, the transistor (Tr_1) turns on. When the voltage exceeds the standard value, the Zener diode goes on and the transistor (Tr_1) turns off.

With the repeated turning on and off of the transistor, the output voltage is kept at the standard value. (Refer to the circuit diagram below.)

(2) Charge lamp

When the transistor (Tr_1) is on, the charge lamp key switch is turned to ON, and current flows to R_1 , R_4 and to Tr_1 to light the lamp. When the engine starts to run and output voltage is generated in the stator coil, the current stops flowing to this circuit, turning off the charge lamp.

(3) Circuit diagram

4-6 Handling precautions

(1) Be careful of the battery's polarity (+, - terminals), and do not connect the wrong terminals to the wrong cables, or the battery will be short-circuited by the generator diode.

In this case too much current will flow, the IC regulator and diodes burn out, and the wire harness will burn.

(2) Make sure of the correct connection of each terminal.

(3) When quick-charging, etc., disconnect either the battery terminal on the AC generator or the terminal on the battery.

(4) Do not short-circuit the terminals.

(5) Do not conduct any tests using high tension insulation resistance. (The diodes and IC regulator will burn out.)

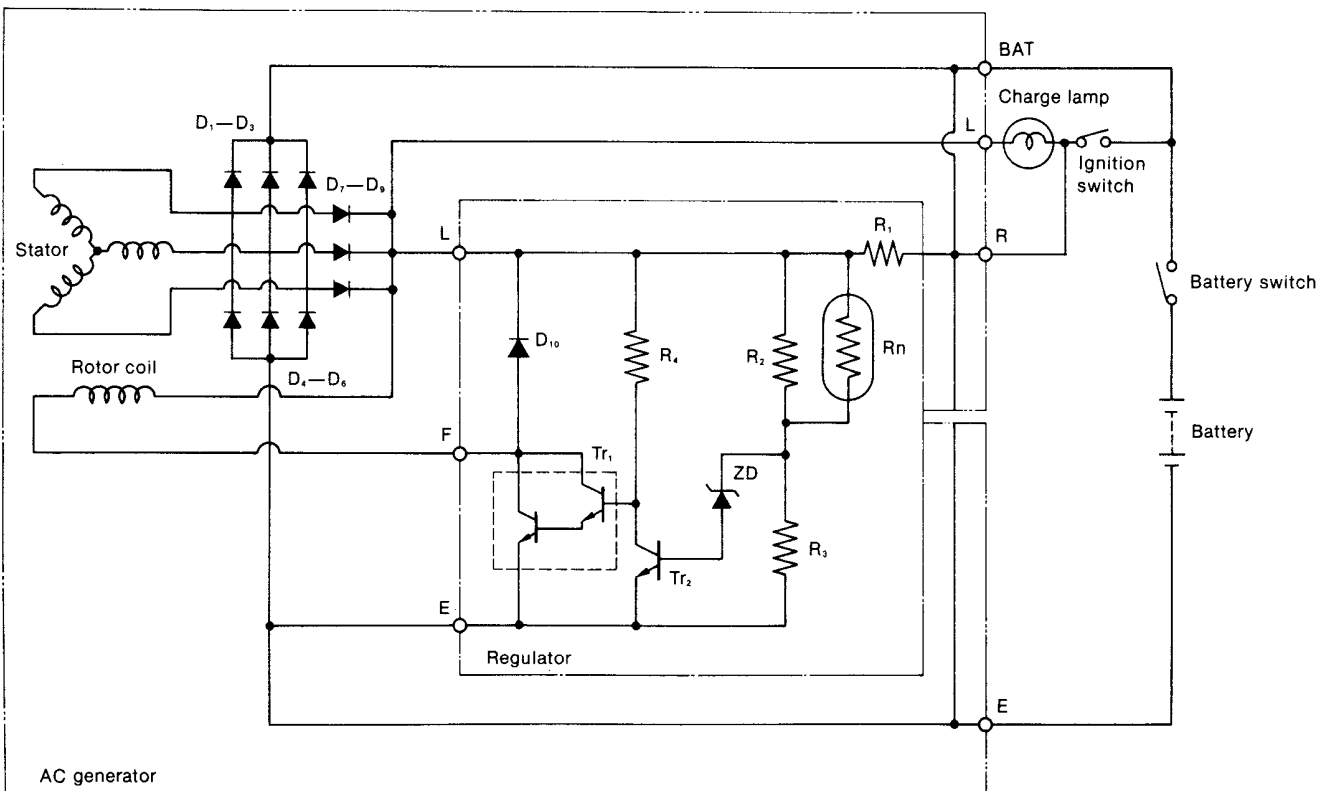

BAT:	Generator output terminal	D_1-D_6 :	Output commutation diode
D_{10} :	IC protecting diode	R_1-R_4 :	Resistor
L:	Charge lamp terminal	D_7-D_8 :	Charging lamp switching diode
ZD:	Zener diode	F:	To supply current to rotor coil
E:	Earth	R_n :	Thermistor (Temperature gradient resistance)
Tr_1, Tr_2 :	Transistor		

4-7 Disassembling the alternator

- (1) Remove the through-bolt, and separate the front assembly from the rear assembly.

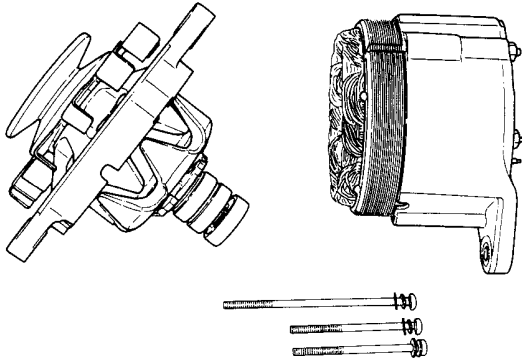

- (4) Remove the nut, the brush-holder, and diode fixing nut at the BAT, and the terminal screws of the rear cover. Separate the rear cover from the stator (with the diode and brush holder).

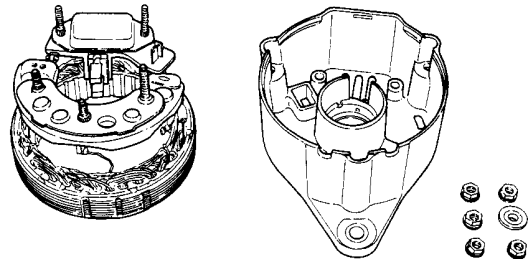

- (2) Remove the pulley nut, and pull out the rotor from the front cover.

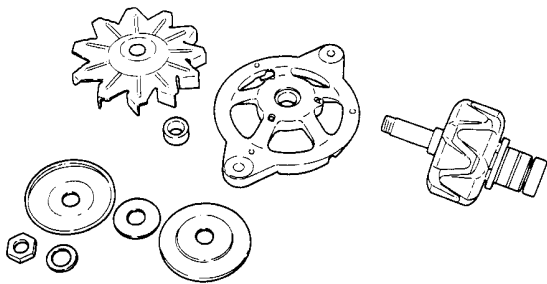

- (5) Disconnect the soldered joint of the stator lead wire, and remove the diode and brush regulator assemblies from the stator at the same time.

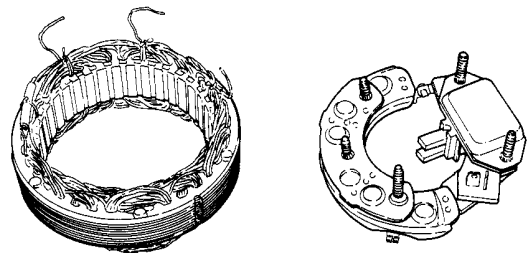

- (3) Remove the $\varnothing 5\text{mm}$ ($\varnothing 0.1969\text{in.}$) screw from the front cover, and then remove the ball bearing.

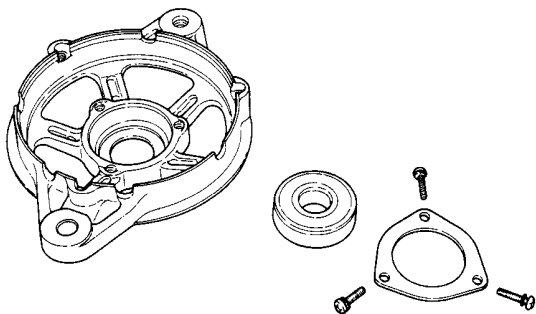

- (6) Separating the regulator

- 1) To separate the regulator, remove the $\varnothing 3\text{mm}$ ($\varnothing 0.1181\text{in.}$) rivet which keeps the diode assembly and the brushless regulator in place, and the soldered joint of the L-terminal.

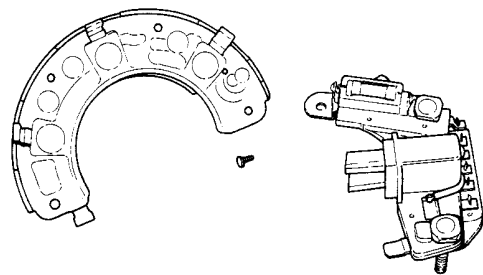

2) To replace the IC regulator, disconnect the soldered joint of the IC regulator and pull out the two bolts. Do not remove these two bolts except when replacing the IC regulator.

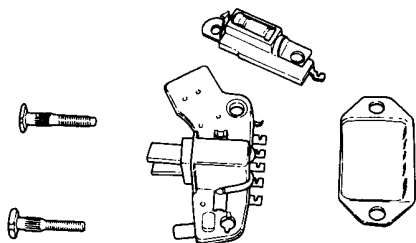

After repeating the above test, if any diode is found to be defective, replace the diode assembly. Since there is no terminal on the auxiliary diode, check the continuity between both ends of the diode.

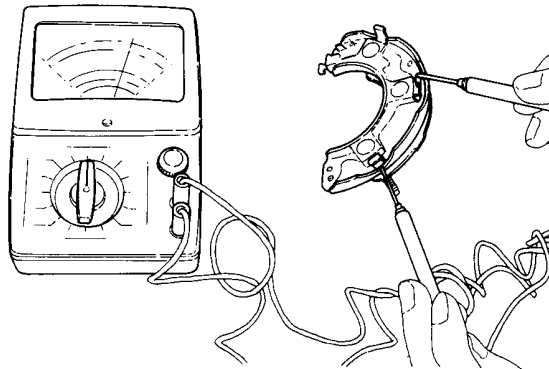

4-8 Inspection and adjustment

(1) Diode

Between terminals		BAT (+ side diode)	
	Tester wire	+ side	- side
U.V.W.	+ side	Continuity	No continuity
	- side		No continuity

Between terminals		E (- side diode)	
	Tester wire	+ side	- side
U.V.W.	+ side	No continuity	Continuity
	- side		Continuity

CAUTION: Do not use high tensile insulation resistance such as meggers, etc. for testing. The diode may burn out.

(2) Rotor

Inspect the slip ring surface, rotor coil continuity and insulation.

1) Inspecting the slip ring surface

Check if the surface of the slip ring is sufficiently smooth. If the surface is rough, grind the surface with No. 500—600 sand paper. If it is contaminated with oil, etc., wipe the surface clean with alcohol.

Slip ring outer dia.	Standard	Wear limit
	ø31.6mm (1.2441in.)	ø30.6mm (1.2049in.)

2) Rotor coil continuity test

Check the continuity in the slip ring with the tester. If there is no continuity, there is a wire break. Replace the rotor coil.

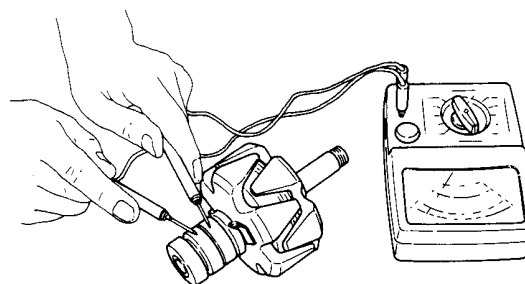

Resistance value	Approx. 3.34Ω at 20°C
------------------	-----------------------

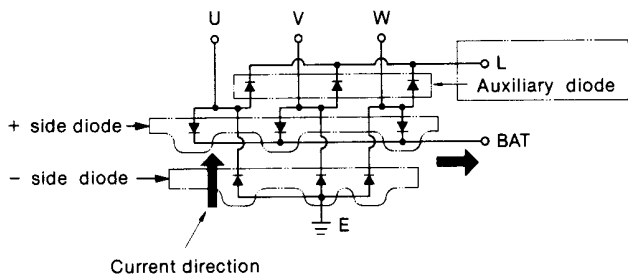

U.V.W.: terminal from the stator coil

Current flows only in one direction in the diode as shown in Fig. 181. Accordingly, when there is continuity between each terminal (e.g. BAT and U), the diode is in normal condition (photo). When there is no continuity, the diode is defective.

When the tester is connected in the reverse of above, there should be no continuity. If there is, the diode is defective.

3) Rotor coil insulation test

Check the continuity between the slip ring and the rotor core, or the shaft. If there is continuity, insulation inside the rotor is defective, causing a short with the earth circuit. Replace the rotor coil.

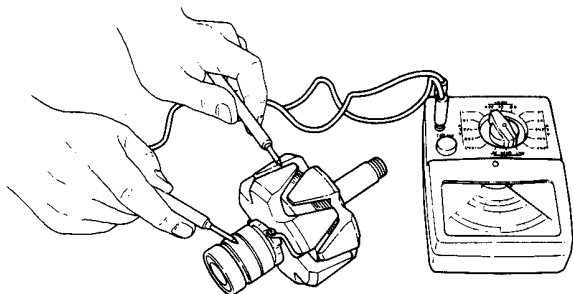

2) Stator coil insulation test

Check the continuity between the terminals and the stator core. If there is continuity, insulation of the stator coil is defective. This will cause a short-circuit with the earth core. Replace the stator coil.

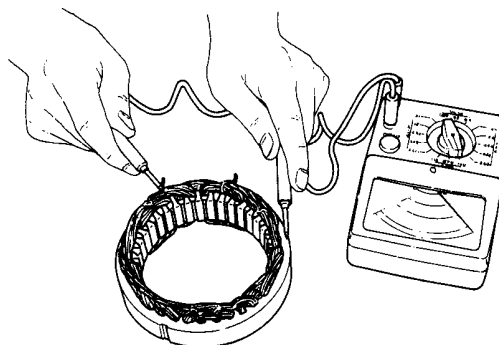

4) Check the rear side ball bearing. If the rotation of the bearing is heavy, or produces abnormal sounds, replace the ball bearing.

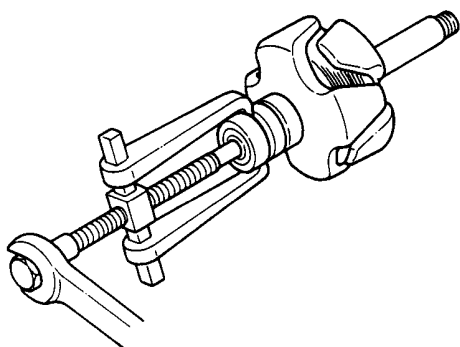

(4) Brush

The brush is hard and wears slowly, but when it is worn beyond the allowable limit, replace it. When replacing the brush, also check the strength of the brush spring. To check, push the spring down to 2mm (0.0787in.) from the end surface of the brush holder, and read the gauge.

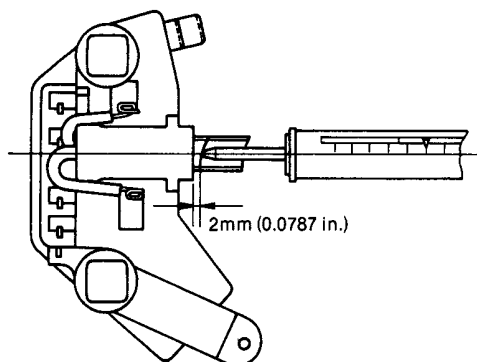

(3) Stator

1) Stator coil continuity test

Check the continuity between each terminal of the stator coil. If there is no continuity, there is a wire break in the stator coil. Replace the stator coil.

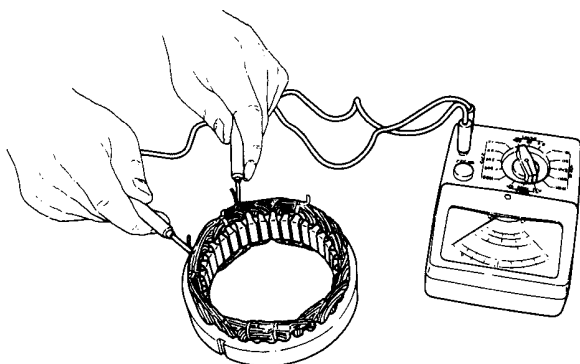

Brush spring strength	255—345g (0.56 ~ 0.76lb.)
-----------------------	---------------------------

(5) Brush wear

Check the brush length. The brush wears very little, but replace the brush if worn over the wear limit line printed on the brush.

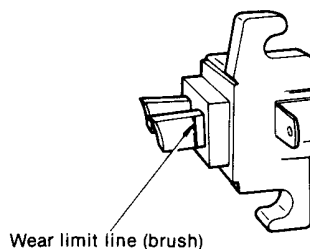

Resistance value	Approx. 0.077Ω at 20°C 1-phase resistance
------------------	--

	mm (in.)	
	Maintenance standard	Wear limit
Brush length	16 (0.6299)	9 (0.3543)

(6) IC regulator

Connect the variable resistance, two 12V batteries, resistor, and voltmeter as shown in the diagram.

1) Use the following measuring devices.

- Resistor (R₁) 100Ω, 2W, 1pc.
- Variable resistor (R_v) 0—300Ω, 12W, 1pc.
- Battery (BAT₁, BAT₂) 12V, 2pcs.
- DC voltmeter 0—30V, 0.5 class 1pc.
(measure at 3 points)

2) Check the regulator in the following sequence, according to the diagram.

- a) Check V₃ (BAT₁ + BAT₂ voltage). If the voltage is 20—26V, both BAT₁ and BAT₂ are normal.
- b) While measuring V₂ (F-E terminal voltage), move R_v gradually from the 0-position. Check if there is a point where the V₂ voltage rises sharply from below 2.0V to over 2.0V. If there is no such point, the regulator is defective. Replace the regulator. If there is a sharp voltage rise when testing, return the R_v to the 0-position, and connect the voltmeter to the V₁ position.
- c) While measuring V₁ (voltage between L-E terminals), move R_v gradually from the 0-position. There should be a point where the voltage of V₁ rises sharply by 2—6V. Measure the voltage of V₁ just before this sharp voltage rise. This is the regulating voltage of the regulator. If this voltage of V₁ is within the standard limit, the regulator is normal. If the voltage deviates from the limit, the regulator is defective. Replace the regulator.

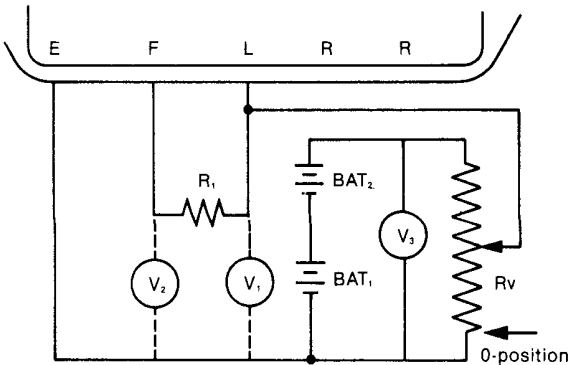

4-9 Reassembling the alternator

Reassembly is done in the reverse order of disassembly. For reassembly, be careful of the following points. (Refer to 4—7 disassembling alternator).

(1) Assembling the brush regulator

1) Solder the brush.

Position the brush as shown in the drawing and solder it. Be careful not to let the solder drip into the pig tail (lead wire).

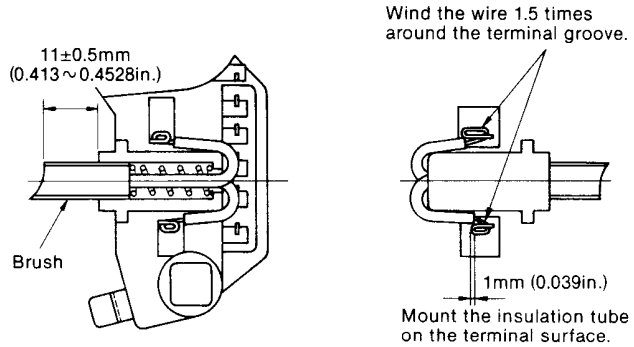

- NOTES: 1. Use non-acid type paste.
2. The soldering iron temperature is 300 ~ 350°C.

- 2) Mount the IC regulator on the brush holder as illustrated, and press in the M5 bolt. Do not forget to assemble the bushing and the connecting plate at the same time.
(If the bushing is left out, the output terminal will be earthed and the battery short-circuited).

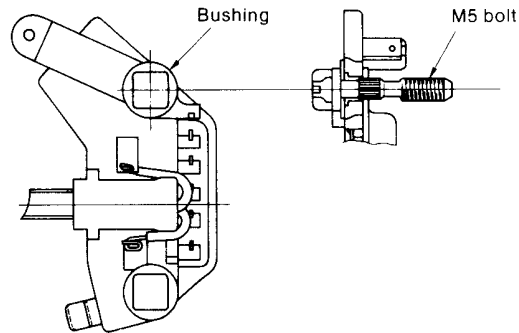

- NOTES: 1. Insertion pressure is 100kg (220.5 lbs.)
2. Insert vertically.

(2) Connecting the brush regulator assembly and diode

1) Check the rivets

Place the rivets as shown in the figure, and then calk them using the calking tool.

Calking torque	500kg (1102 lbs.)
----------------	-------------------

2) Connect the brush to the diode.

Insert the brush side terminal into the diode terminal, calk it, and then solder into place.

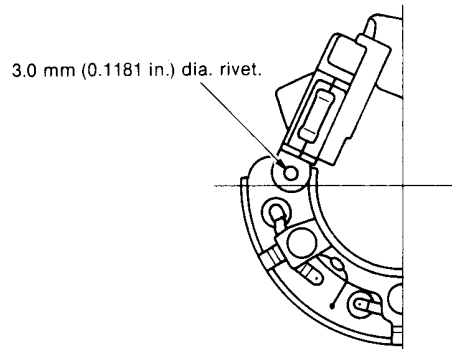

Rivetting pressure	500kg (1102 lbs.)
--------------------	-------------------

(3) Assembling the rear cover

Insert pins from the outside of the rear cover. Install the brush on the brush holder, then attach the rear cover. After assembly, pull out the pins.

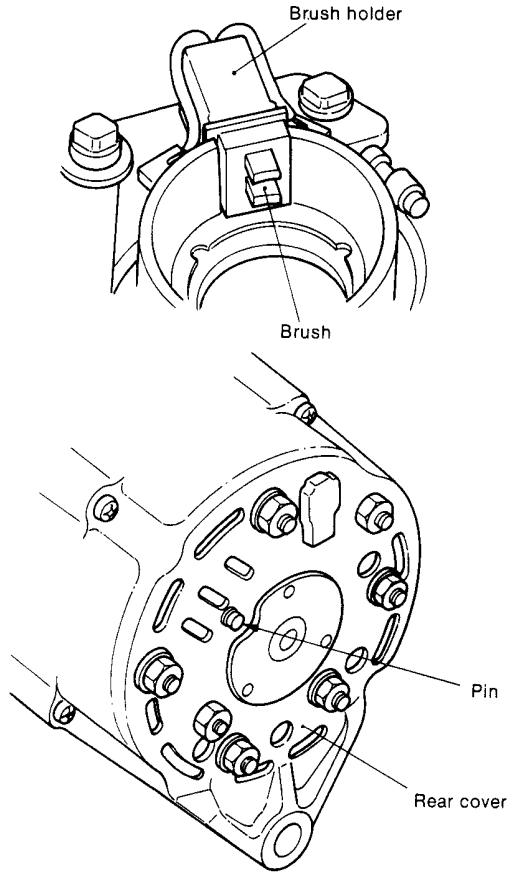

(4) Tightening torques

Positions	Tightening torque kg-cm (ft-lb)
Brush holder fixing	32—40 (2.31 ~ 2.89)
Diode fixing	32—40 (2.31 ~ 2.89)
Bearing retainer fixing	32—40 (2.31 ~ 2.89)
Pulley nut tightening	400—600 (28.93 ~ 43.40)
Through-bolt tightening	32—40 (2.31 ~ 2.89)

4-10 Performance test

Conduct a performance test on the reassembled AC generator as follows. The following is the circuit for the performance test.

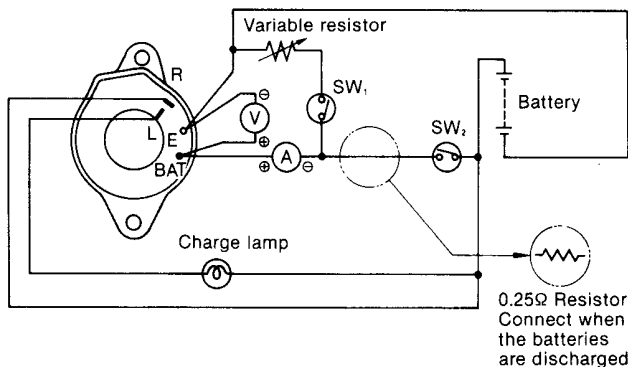

(1) Measuring devices

DC voltmeter	0—15V or 0—30V, 0.5 Class, 1pc.
DC ammeter	0—100A, 1.0 Class, 1pc.
Variable resistor	0—0.25Ω, 1kW, 1pc.
Lamp	12V, 3W
100Ω resistor	3W
0.25Ω resistor	25W

(2) Measuring the regulating voltage

- 1) When measuring devices are connected in the performance test circuit as shown above, the charge lamp lights.
- 2) Close SW₂ while keeping SW₁ open and run the AC generator. When the revolutions of the generator are gradually raised, the charge lamp goes off.
- 3) Raise the revolutions of the AC generator, and read the voltmeter gauge when the revolutions reach about 5,000 rpms.

NOTES: 1. Make sure that the ammeter indication at this time is less than 5A. If the indication is over 5A, connect the 0.25Ω resistor. The voltmeter indication at this time must be within the prescribed regulating voltage value.

2. Raise the AC generator revolutions high to make sure the regulating voltage does not fluctuate along with changes in the revolution speed.

(3) Precautions for measuring the regulating voltage

- 1) When measuring the voltage, measure the voltage between the AC generator BAT terminal, or Battery + terminal, and AC generator E-terminal.
- 2) Use a fully charged battery.
- 3) Measure the voltage quickly.
- 4) Keep SW, open for measurement.

4-11 Troubleshooting

(1) Charging failure

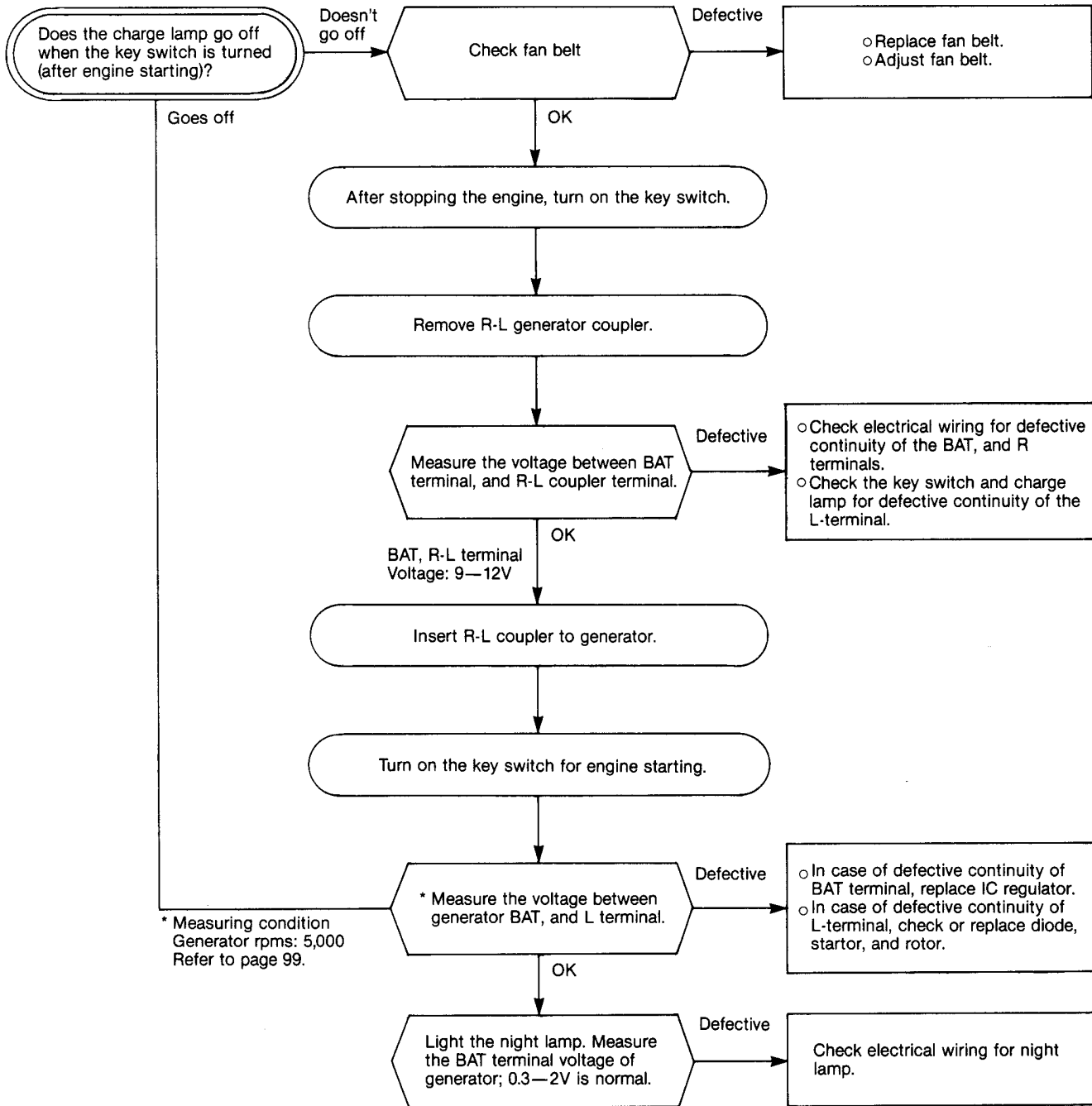

(2) Overcharging

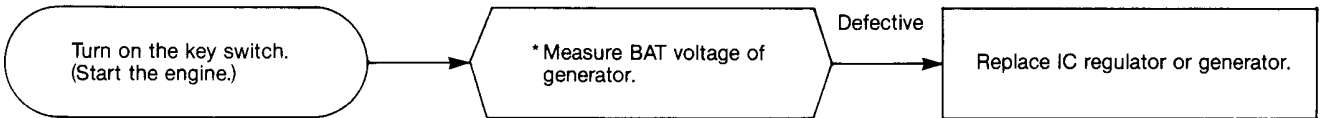

(3) Charge lamp failure

