

WORKSHOP MANUAL ENGINE BASE

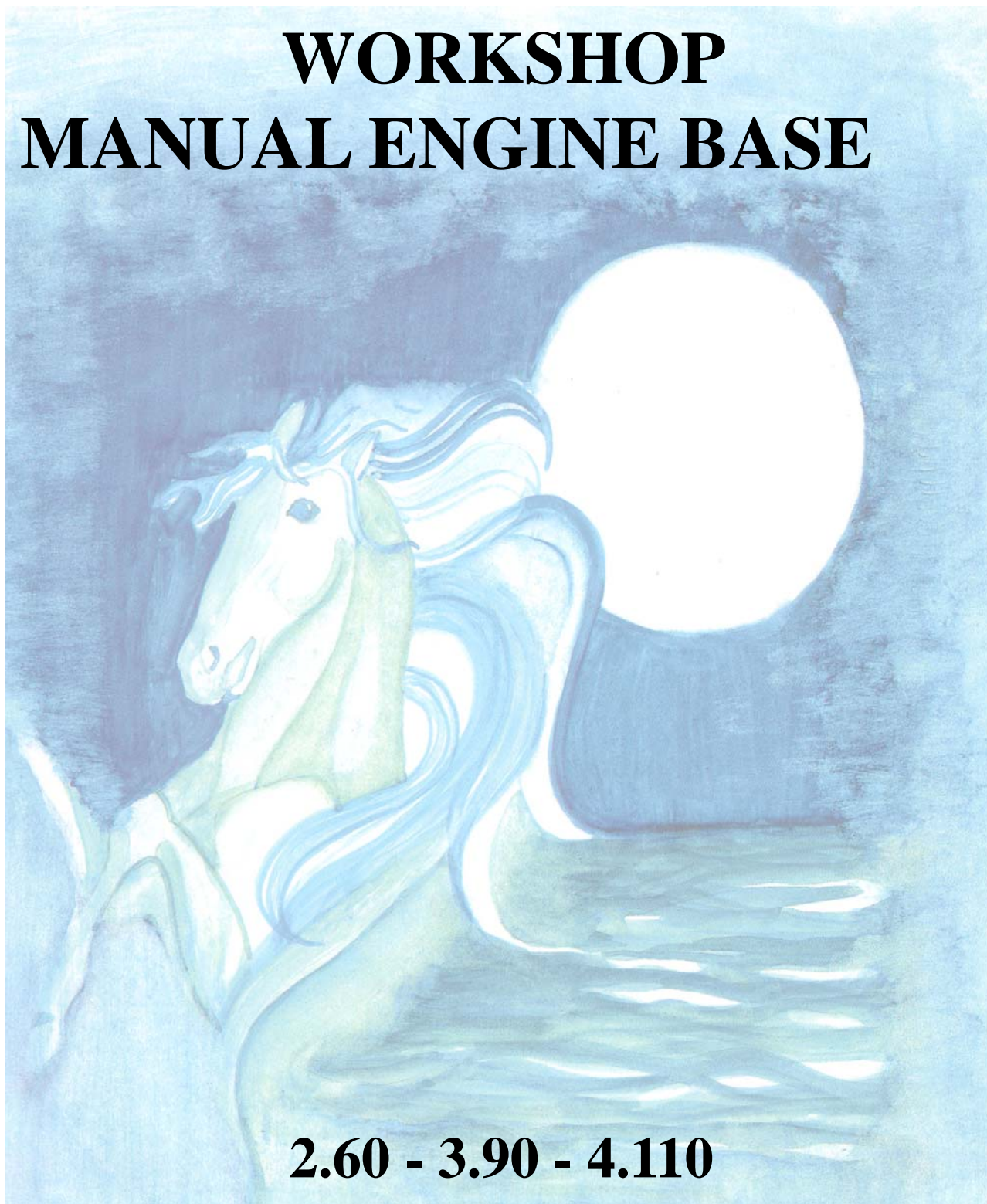

2.60 - 3.90 - 4.110

nannidiesel

energy in blue

NANNI INDUSTRIES S.A.S – Zone Industrielle
11 avenue MARIOTTE
B.P.107 – 33260 LA TESTE - FRANCE

6030059

TO THE READER

This Workshop Manual has been prepared to provide servicing personnel with information on the mechanism, service and maintenance of KUBOTA Diesel Engines 70 mm STROKE SERIES. It is divided into two parts, "Mechanism" and "Disassembling and Servicing".

■ Mechanism

Information on construction and functions are included for each engine section. This part should be understood before proceeding with troubleshooting, disassembling and servicing.

■ Disassembling and Servicing

Under the heading "General" come general precautions, troubleshooting, lists of servicing specifications and periodic inspection items. For each engine section, there are "Checking and Adjustment", "Disassembling and Assembling", and "Servicing" which cover procedures, precautions, factory specification and allowable limits.

All information, illustrations and specifications contained in this manual are based on the latest production information available at the time of publication. The right is reserved to make changes in all information at any time without notice.

Due to covering many models of this manual, illustration or picture being used have not been specified as one model.

Apr. 1990

© KUBOTA Corporation 1990

CONTENTS

SPECIFICATIONS	1
PERFORMANCE CURVES	3
DIMENSIONS	6

M. MECHANISM

F. FEATURE	M-1	[2] WATER PUMP	M-10
1. ENGINE BODY	M-3	[3] THERMOSTAT	M-11
[1] CYLINDER BLOCK	M-3	[4] RADIATOR	M-11
[2] CYLINDER HEAD	M-3	[5] RADIATOR CAP	M-11
[3] CRANK SHAFT	M-4	4. INTAKE/EXHAUST SYSTEM	M-12
[4] PISTON AND PISTON RINGS	M-4	[1] AIR CLEANER	M-12
[5] CONNECTING ROD	M-4	[2] MUFFLER	M-12
[6] CAMSHAFT	M-5	5. FUEL SYSTEM	M-13
[7] FLYWHEEL	M-5	[1] GENERAL	M-13
[8] ROCKER ARM	M-5	[2] INJECTION PUMP	M-13
2. LUBRICATING SYSTEM	M-6	[3] INJECTION NOZZLE	M-15
[1] GENERAL	M-6	[4] FUEL LIFT PUMP	M-16
[2] OIL PUMP	M-8	[5] FUEL FILTER	M-16
[3] RELIEF VALVE	M-8	[6] GOVERNOR	M-17
[4] OIL FILTER CARTRIDGE	M-9	6. ELECTRICAL SYSTEM	M-19
[5] OIL PRESSURE SWITCH	M-9	[1] GENERAL	M-19
3. COOLING SYSTEM	M-10	[2] CHARGING SYSTEM	M-19
[1] GENERAL	M-10		

S. DISASSEMBLING AND SERVICING

G. GENERAL	S-1	2. LUBRICATING SYSTEM	S-48
[1] ENGINE IDENTIFICATION	S-1	CHECKING	S-48
[2] GENERAL PRECAUTIONS	S-2	DISASSEMBLING AND ASSEMBLING	S-48
[3] TIGHTENING TORQUES	S-3	SERVICING	S-49
[4] TROUBLESHOOTING	S-4	[1] OIL PUMP	S-49
[5] SERVICING SPECIFICATIONS	S-6	3. COOLING SYSTEM	S-50
[6] MAINTENANCE CHECK LIST	S-12	CHECKING	S-50
[7] CHECK AND MAINTENANCE	S-13	[1] FAN BELT	S-50
[8] SPECIAL TOOLS	S-18	[2] RADIATOR	S-50
1. ENGINE BODY	S-23	DISASSEMBLING AND ASSEMBLING	S-51
CHECKING AND ADJUSTING	S-23	4. FUEL SYSTEM	S-52
DISASSEMBLING AND ASSEMBLING	S-24	CHECKING AND ADJUSTING	S-52
[1] DRAINING WATER AND OIL	S-24	[1] INJECTION PUMP	S-52
[2] EXTERNAL COMPONENTS	S-24	[2] INJECTION NOZZLE	S-53
[3] CYLINDER HEAD AND VALVES	S-24	DISASSEMBLING AND ASSEMBLING	S-54
[4] GEAR CASE	S-27	[1] INJECTION PUMP	S-54
[5] PISTON AND CONNECTING ROD	S-31	[2] INJECTION NOZZLE	S-54
[6] FLYWHEEL AND CRANKSHAFT	S-33	5. ELECTRICAL SYSTEM	S-55
SERVICING	S-36	CHECKING	S-55
[1] CYLINDER HEAD	S-36	[1] ALTERNATOR AND REGULATOR	S-55
[2] TIMING GEAR AND CAMSHAFT	S-39	[2] STARTER	S-55
[3] PISTON AND CONNECTING ROD	S-41	[3] GLOW PLUG	S-56
[4] CRANKSHAFT	S-42	DISASSEMBLING AND ASSEMBLING	S-56
[5] CYLINDER LINER	S-46	[1] STARTER	S-56
		SERVICING	S-57
		[1] STARTER	S-57

SPECIFICATIONS

Model		Z500-B	Z600-B	ZH600-B	D650-B	D750-B
Number of Cylinders		2			3	
Type		Vertical, water-cooled, 4-cycle diesel engine				
Bore × Stroke mm (in.)		68 × 70 (2.68 × 2.76)	72 × 70 (2.83 × 2.76)		64 × 70 (2.52 × 2.76)	68 × 70 (2.68 × 2.76)
Total Displacement cm ³ (cu.in.)		508 (31.00)	570 (34.78)		675 (41.2)	762 (46.5)
Brake Horsepower	SAE Net Cont. kW/min ⁻¹ (rpm) (HP/min ⁻¹ (rpm))	6.3/3000 (8.5/3000)	8.2/3200 (11/3200)	8.6/3600 (11.5/3600)	8.6/3000 (11.5/3000)	9.7/3000 (13.0/3000)
	SAE Net Intermittent kW/min ⁻¹ (rpm) (HP/min ⁻¹ (rpm))	7.46/3000 (10.0/3000)	9.3/3200 (12.5/3200)	10.4/3600 (14.0/3600)	9.7/3000 (13.0/3000)	11.2/3000 (15.0/3000)
	SAE Gross Intermittent kW/min ⁻¹ (rpm) (HP/min ⁻¹ (rpm))	8.2/3000 (11.0/3000)	10.4/3200 (13.8/3200)	11.5/3600 (15.5/3600)	11.2/3000 (14.3/3000)	12.7/3000 (16.5/3000)
	DIN6271-NA kW/min ⁻¹ (rpm) (PS/min ⁻¹ (rpm))	6.25/3000 (8.5/3000)	8.1/3200 (11.0/3200)	8.5/3600 (11.5/3600)	8.5/3000 (11.5/3000)	9.6/3000 (13.0/3000)
	DIN6271-NB kW/min ⁻¹ (rpm) (PS/min ⁻¹ (rpm))	7.0/3000 (9.5/3000)	8.8/3200 (12.0/3200)	9.9/3600 (13.5/3600)	9.2/3000 (12.5/3000)	10.7/3000 (14.5/3000)
	DIN70020 kW/min ⁻¹ (rpm) (PS/min ⁻¹ (rpm))	7.7/3000 (10.5/3000)	9.6/3200 (13.0/3200)	10.7/3600 (14.5/3600)	10.3/3000 (14.0/3000)	11.8/3000 (16.0/3000)
Maximum Bare Speed min ⁻¹ (rpm)		3200	3500	3780	3200	
Minimum Idling Speed min ⁻¹ (rpm)		800				
Maximum torque N·m/min ⁻¹ (rpm) kgf·m/min ⁻¹ (rpm) ft-lbs/min ⁻¹ (rpm)		28.0/1800 2.86/1800 20.72/1800	32.9/2000 3.36/2000 24.29/2000	33.2/2000 3.39/2000 24.52/2000	36.5/1800 3.72/1800 26.94/1800	42.2/1800 4.30/1800 31.08/1800
Combustion Chamber		Spherical Type				
Fuel Injection Pump		Bosch K Type Mini Pump				
Governor		Centrifugal Ball Mechanical Governor				
Direction of Rotation		Counter-clockwise (viewed from flywheel side)				
Injection Nozzle		Bosch Throttle Type				
Injection Timing		0.44 rad. (25°) before T.D.C.				
Firing Order		1-2			1-2-3	
Injection Pressure		13.73 MPa (140 kgf/cm ² , 1991 psi)				
Compression Ratio		22 : 1				
Lubricating System		Forced Lubrication by Pump				
Oil Pressure Indicating		Electrical Type Switch				
Lubricating Filter		Full Flow Paper Filter (Cartridge Type)				
Cooling System		Pressurized Radiator, Forced Circulation with Water Pump (Not included in the basic engine)				
Starting System V, kW		Electric Starting with Starter (12, 0.8)				
Starting Support Device		By Glow Plug in Combustion Chamber				
Battery		12 V, 45 AH, equivalent			12 V, 65 AH, equivalent	
Dynamo for Charging		12 V, 150 W				
Fuel		Diesel Fuel No. 2-D (ASTM D975)				
Lubricating Oil		Class CF lubricating oil as per API classification is recommended. If this class of lubricating oil is not available, preferably use Class CD or CE lubricating oil. For details on recommended lubricating oils.				
Lubricating Oil Capacity L		2.55 (2.70 U.S.qts., 2.24 Imp.qts.)			4.6 (4.86 U.S.qts., 4.05 Imp.qts.)	
Weight (Dry) kg (lbs)		69.7 (153.7)	70.5 (155.5)		82.6 (182.1)	82.1 (181.0)
Application		General Power Source				

D850-B	DH850-B	D950-B	V1100-B	VH1100-B	V1200-B
3			4		
Vertical, water-cooled, 4-cycle diesel engine					
72 × 70 (2.83 × 2.76)		75 × 70 (2.95 × 2.76)	72 × 70 (2.83 × 2.76)		75 × 70 (2.95 × 2.76)
855 (52.2)		927 (56.6)	1140 (69.56)		1237 (75.49)
11.6/3000 (15.5/3000)	13.1/3600 (17.5/3600)	12.7/3000 (17.0/3000)	15.29/3000 (20.5/3000)	17.15/3600 (23/3600)	16.79/3000 (22.5/3000)
13.4/3000 (18.0/3000)	15.7/3600 (21.0/3600)	14.5/3000 (19.5/3000)	17.90/3000 (24.0/3000)	20.89/3600 (28.0/3600)	19.40/3000 (26.0/3000)
14.9/3000 (19.8/3000)	17.2/3600 (23.0/3600)	16.0/3000 (21.5/3000)	19.77/3000 (26.5/3000)	22.98/3600 (30.8/3600)	21.26/3000 (28.5/3000)
11.4/3000 (15.5/3000)	12.9/3600 (17.5/3600)	12.5/3000 (17.0/3000)	15.08/3000 (20.5/3000)	16.92/3600 (23.0/3600)	16.55/3000 (22.5/3000)
12.5/3000 (17.0/3000)	14.7/3600 (20.0/3600)	13.6/3000 (18.5/3000)	16.55/3000 (22.5/3000)	19.86/3600 (27.0/3600)	18.02/3000 (24.5/3000)
14.0/3000 (19.0/3000)	16.2/3600 (22.0/3600)	15.1/3000 (20.5/3000)	18.39/3000 (25.0/3000)	21.70/3600 (29.5/3600)	19.86/3000 (27.0/3000)
3200	3780	3200	3200	3780	3200
800					
50.6/1800	49.9/2400	55.6/1800	68.45/1800	66.49/2400	74.04/1800
5.16/1800	5.09/2400	5.67/1800	6.98/1800	6.78/2400	7.55/1800
37.30/1800	36.78/2400	41.00/1800	50.45/1800	49.04/2400	54.65/1800
Spherical Type					
Bosch K Type Mini Pump					
Centrifugal Ball Mechanical Governor					
Counter-clockwise (viewed from flywheel side)					
Bosch Throttle Type					
0.44 rad. (25°) before T.D.C.					
1-2-3			1-3-4-2		
13.73 MPa (140 kgf/cm ² , 1991 psi)					
22 : 1					
Forced Lubrication by Pump					
Electrical Type Switch					
Full Flow Paper Filter (Cartridge Type)					
Pressurized Radiator, Forced Circulation with Water Pump (Not included in the basic engine)					
Electric Starting with Starter (12, 0.8)			Electric Starting with Starter (12, 1.0)		
By Glow Plug in Combustion Chamber					
12 V, 65 AH, equivalent			12 V, 80 AH, equivalent		
12 V, 150 W					
Diesel Fuel No. 2-D (ASTM D975)					
Class CF lubricating oil as per API classification is recommended. If this class of lubricating oil is not available, preferably use Class CD or CE lubricating oil. For details on recommended lubricating oils.					
4.6 (4.86 U.S.qts., 4.05 Imp.qts.)	3.7 (3.91 U.S.qts., 3.26 Imp.qts.)	4.6 (4.86 U.S.qts., 4.05 Imp.qts.)	5.7 (6.0 U.S.qts., 5.02 Imp.qts.)		
82.6 (182.1)		83.1 (183.2)	103.3 (227.8)		104 (229.3)
General Power Source					

PERFORMANCE CURVES

Z500-B (SAE)

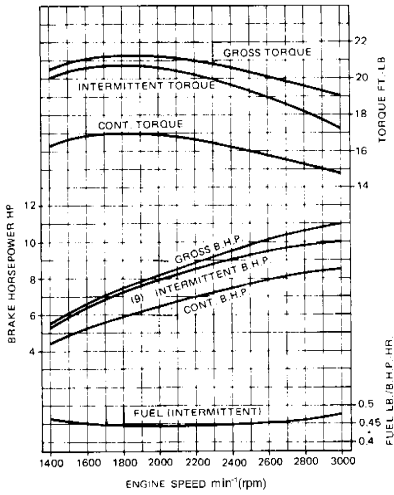

Z600-B (SAE)

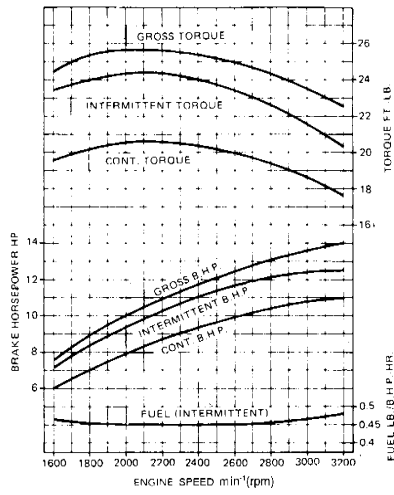

ZH600-B (SAE)

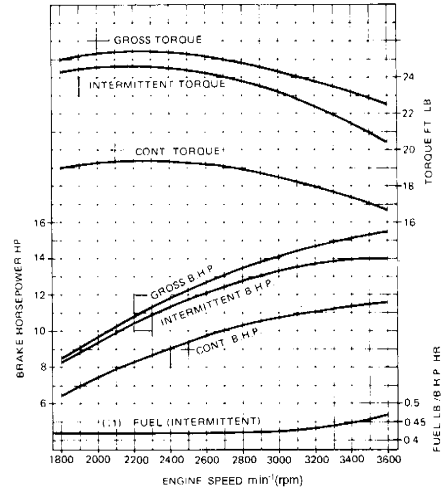

Z500-B (DIN)

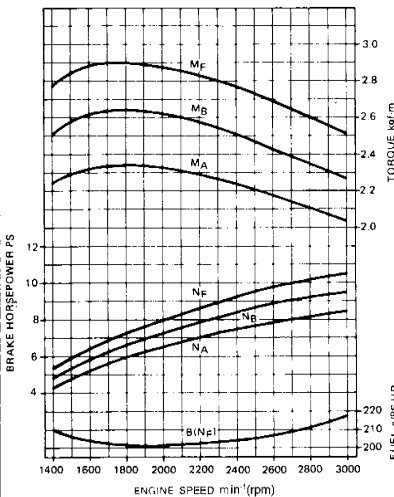

Z600-B (DIN)

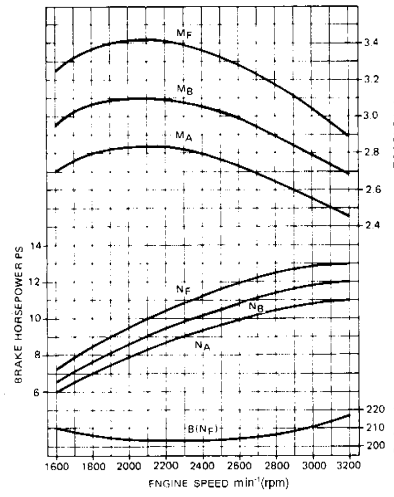

ZH600-B (DIN)

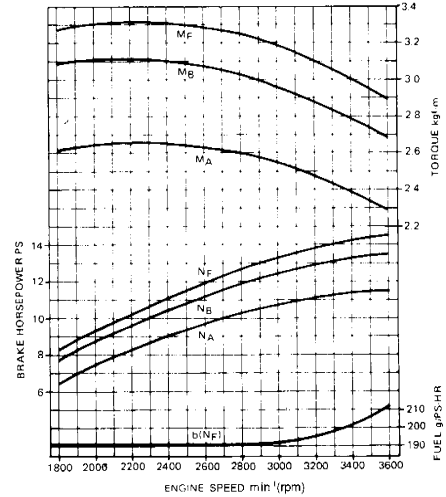

D650-B (SAE)

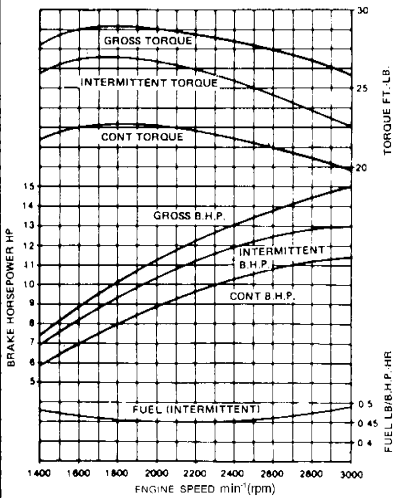

D650-B (DIN)

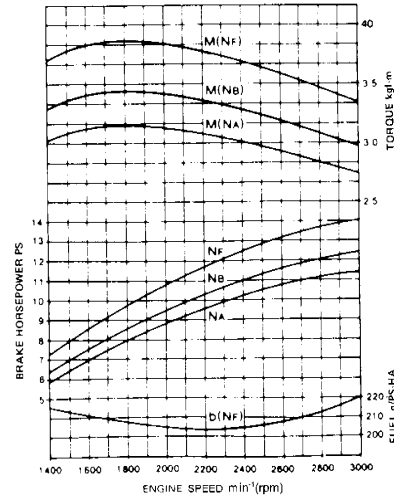

0076F039

0076F034

D750-B (SAE)

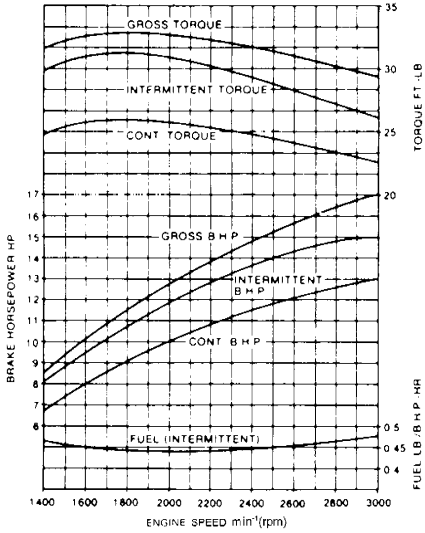

0076F040

D850-B (SAE)

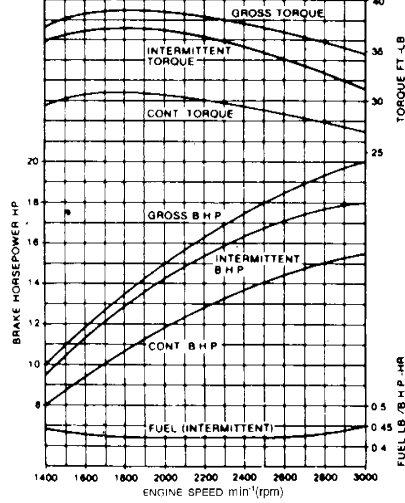

0076F042

DH850-B (SAE)

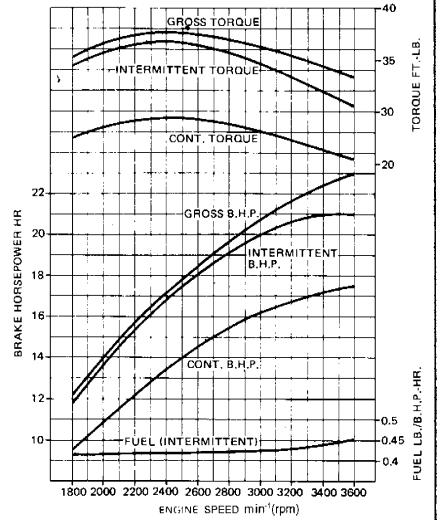

0076F041

D750-B (DIN)

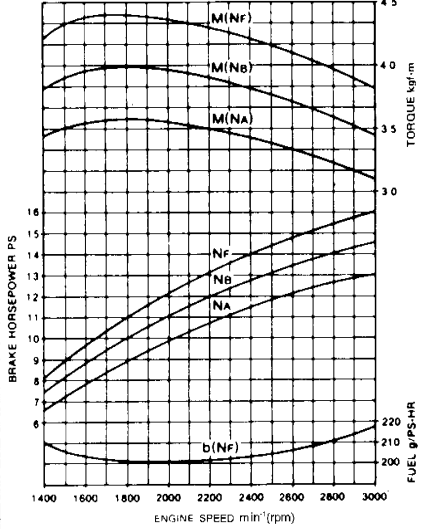

0076F035

D850-B (DIN)

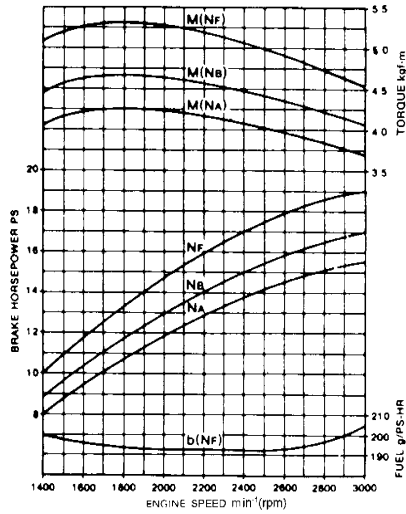

0076F036

DH850-B (DIN)

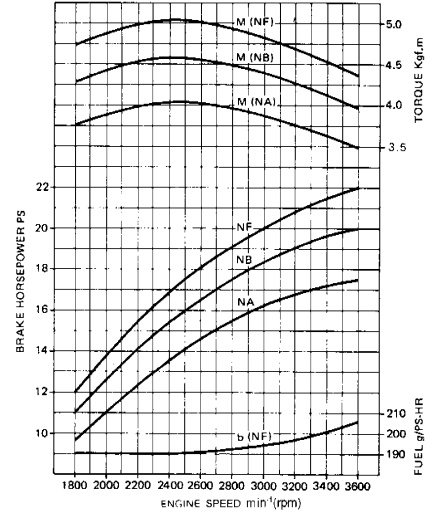

0076F037

D950-B (SAE)

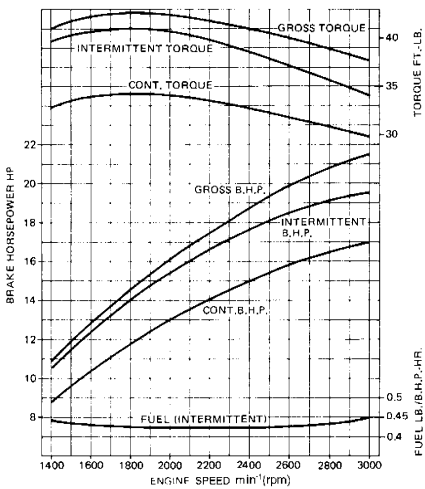

0076F043

D950-B (DIN)

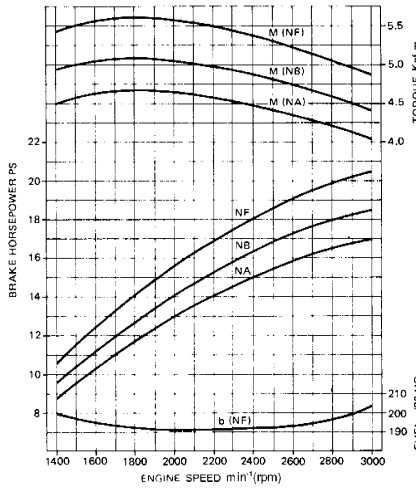

0076F038

V1100-B (SAE)

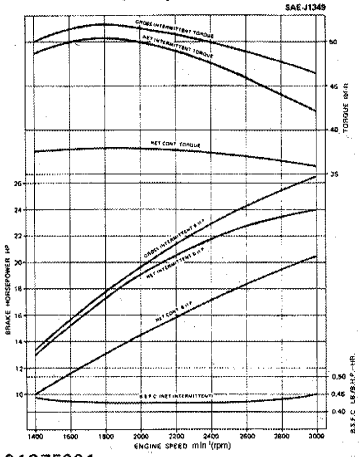

0107F001

V1200-B (SAE)

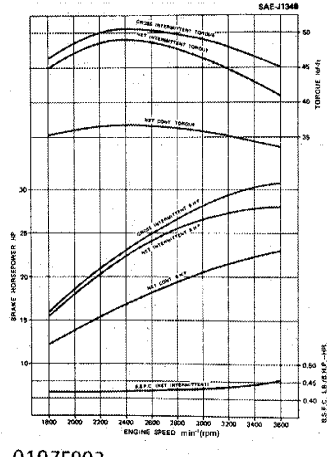

0107F002

VH1100-B (SAE)

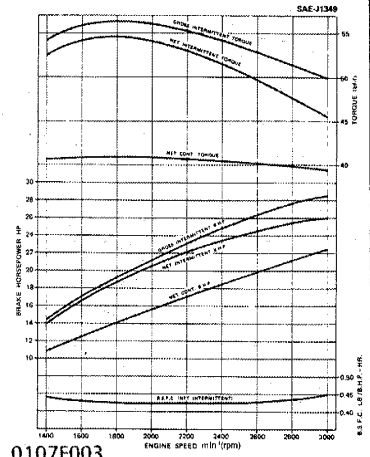

0107F003

V1100-B (DIN)

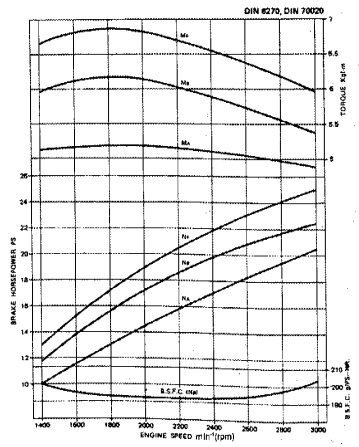

0107F004

VH1100-B (DIN)

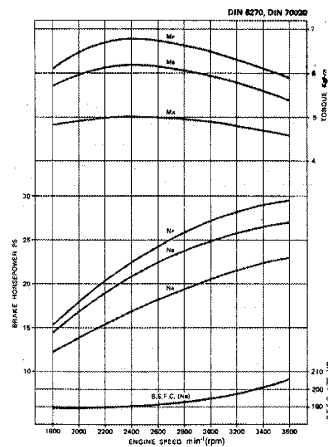

0107F005

V1200-B (DIN)

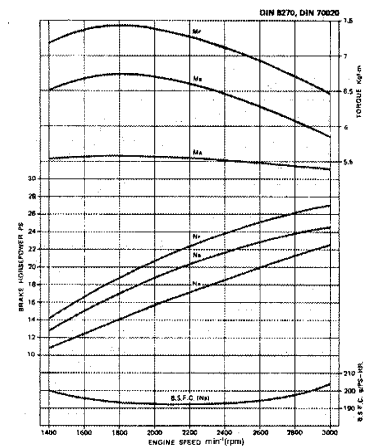

0107F006

NOTE

- Each performance curves, obtained in accordance with DIN 6271.
- Each performance curves, obtained in accordance with SAE J1349.

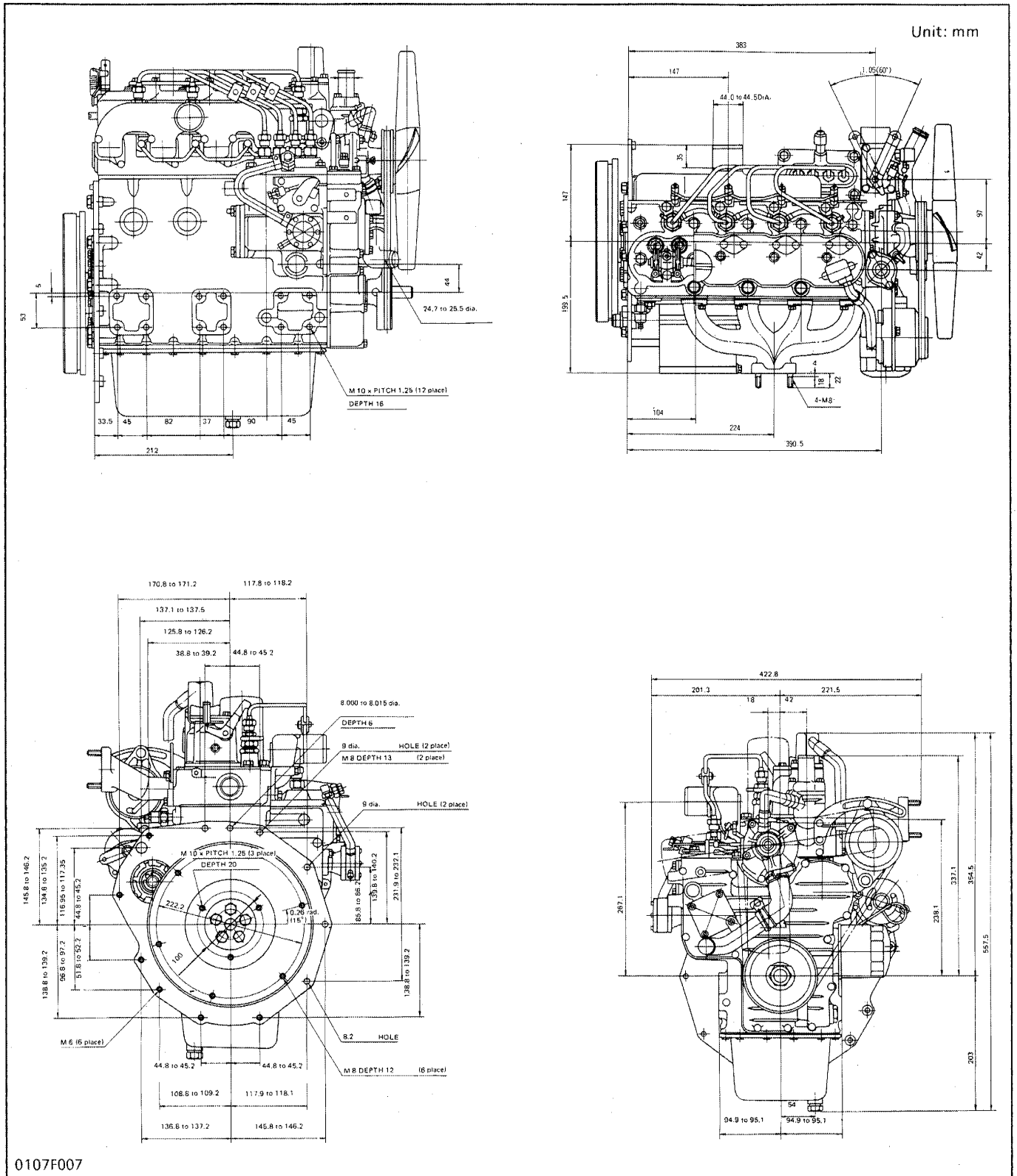

M. MECHANISM

F FEATURE

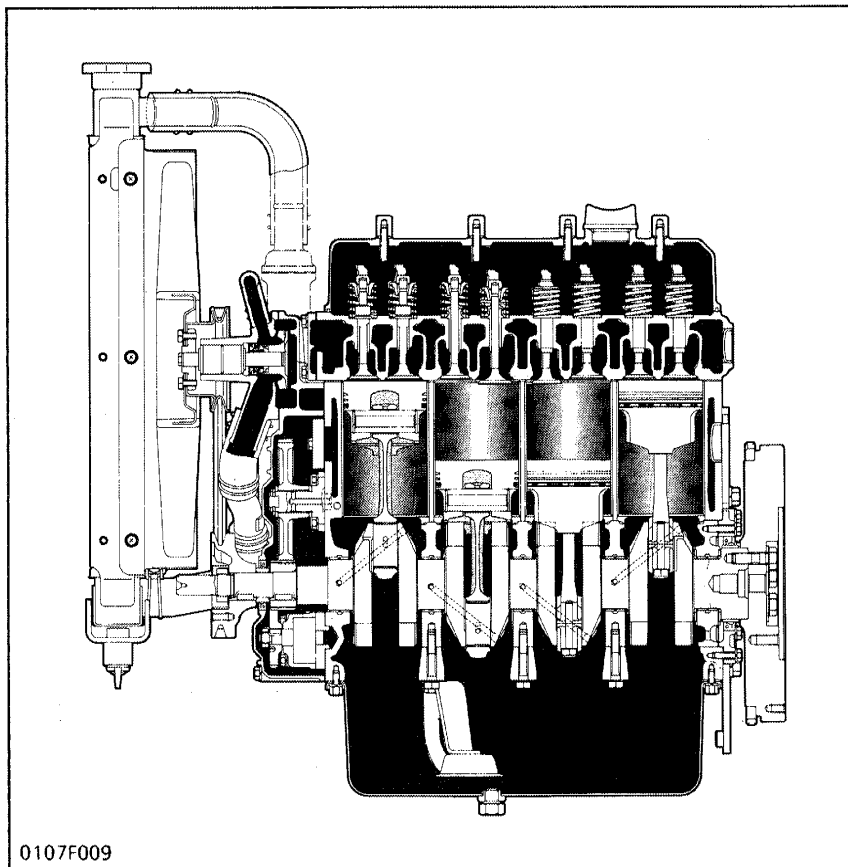
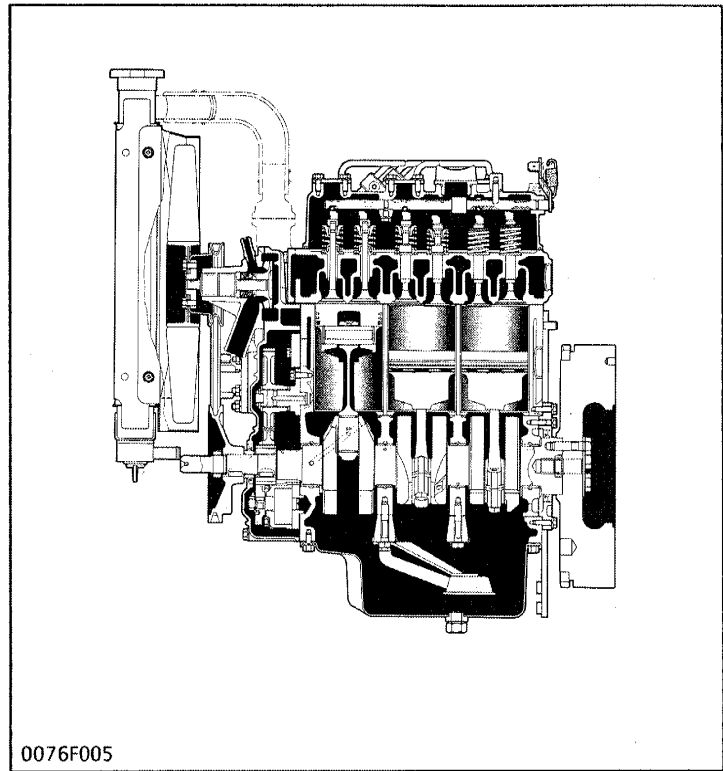
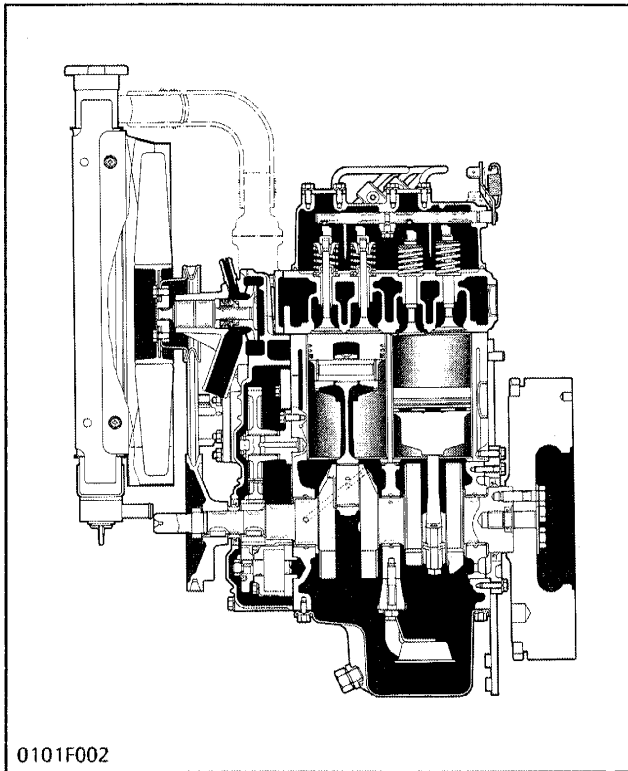

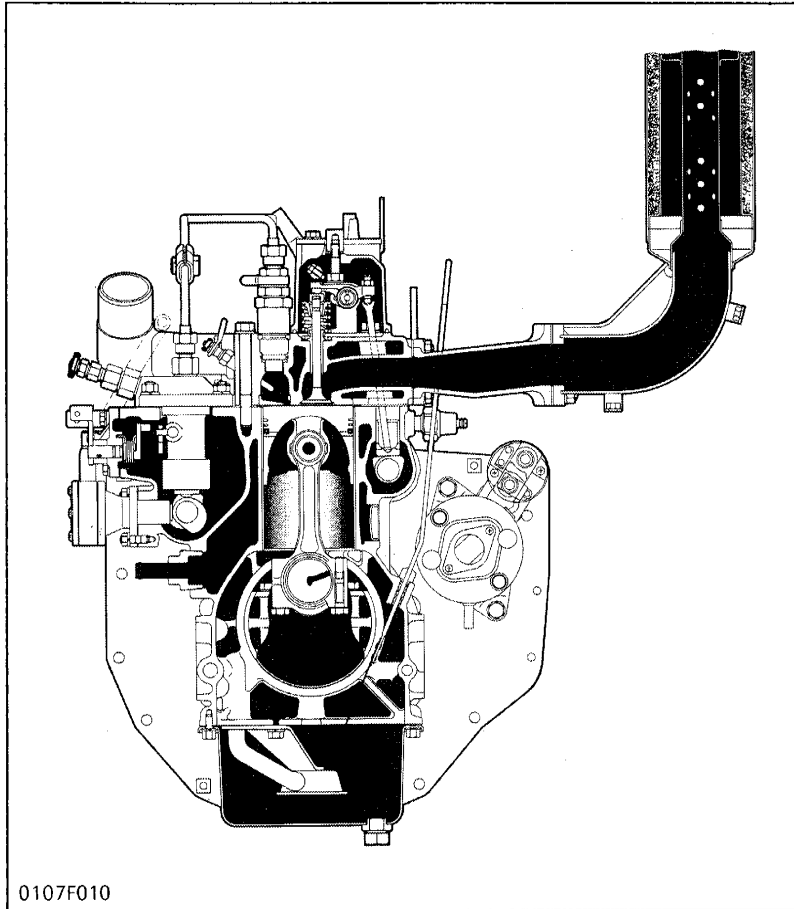

The 70 mm STROKE SERIES ENGINE are vertical, water-cooled, 4-cycle diesel engines.

They are incorporated KUBOTA's foremost technologies. With KUBOTA's spherical combustion chamber, well-known Bosch K type injection pump and the well-balanced designs, they give greater power, low fuel consumption, little vibration and quiet operation.

1 ENGINE BODY

[1] CYLINDER BLOCK

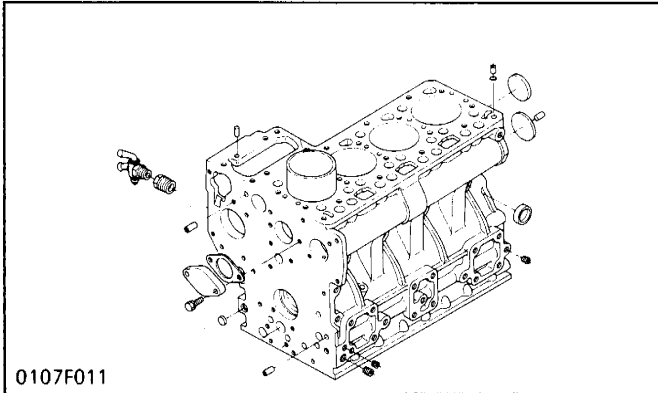

The engine has a high durability tunnel-type cylinder in which the crank bearing component is a constructed body. Furthermore, dry-type cylinder liners, being pressure-fitted into cylinders, allow effective cooling, less distortion, and greater wear-resistance. The noise level is reduced to a minimum because each cylinder has its own chamber.

[2] CYLINDER HEAD

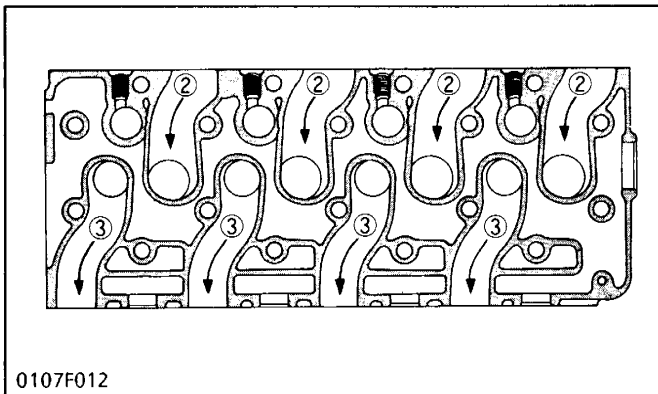

The cross-flow type intake/exhaust ports in this engine have their openings at both sides of the cylinder head. Because overlaps of intake/exhaust ports are smaller than in ports of other types which have openings on one side, the suction air can be protected from being heated and expanded by heated exhaust air. The cool, high density suction air has high volume efficiency and raises the power of the engine. Furthermore, distortion of the cylinder head by heated exhaust gas is reduced because intake ports are arranged alternately. The combustion chamber is of KUBOTA's exclusive spherical combustion chamber type. Suction air is whirled to be mixed effectively with fuel, prompting combustion and reducing fuel consumption.

In the combustion chamber are installed throttle type injection nozzle and rapid heating sheathed type glow plug. This glow plug assures easier than ever engine starts even at -15°C (5°F).

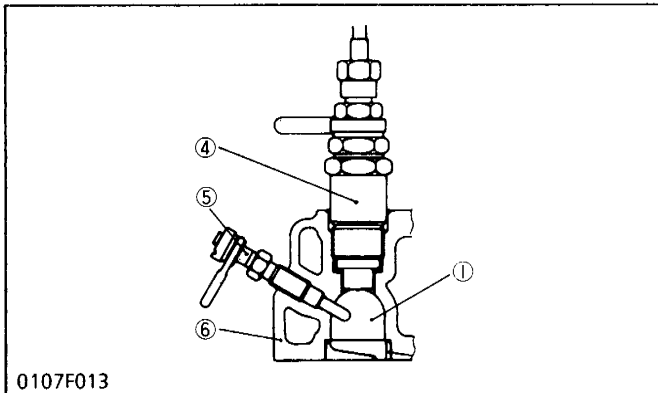

- (1) Combustion Chamber
- (2) Intake Port
- (3) Exhaust Port
- (4) Nozzle Assembly
- (5) Glow Plug
- (6) Cylinder Head

[3] CRANKSHAFT

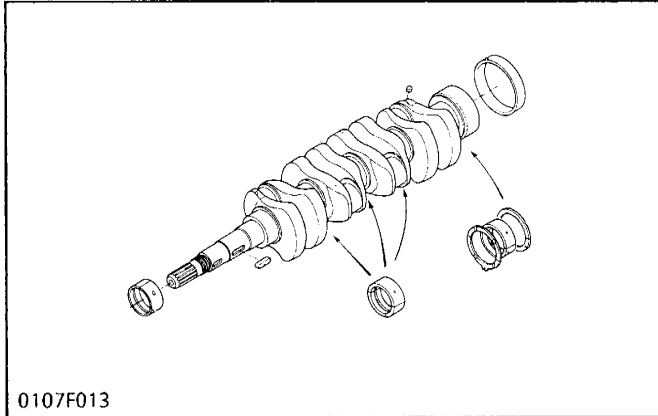

The crankshaft with the connecting rod converts the reciprocating motion of the piston into the rotating motion.

The crankshaft is made of tough special alloy steel, and the journals, pins and oil seal sliding portions are induction hardened to increase the hardness for higher wear resistance.

The front journal is supported by a solid type bearing, the intermediate journal by a split type, and the rear journal by a split type with thrust bearings.

The crankshaft is provided with an oil gallery, through which engine oil is fed to the crank pin portion, and lubricate it.

[4] PISTON AND PISTON RINGS

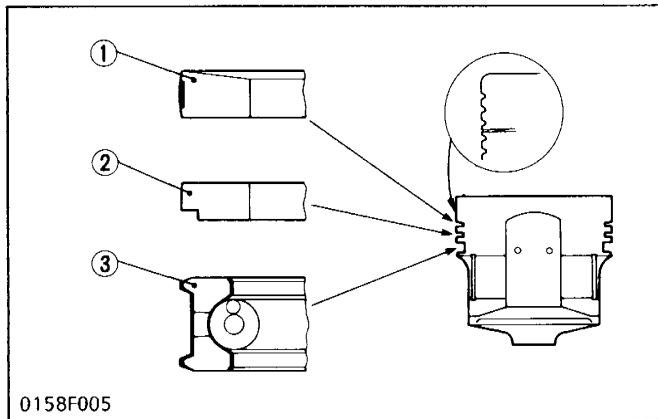

The piston has a slightly oval shape when cold (in consideration of thermal expansion) and a flat head.

Three rings are installed in grooves in the piston.

The top ring (1) is a keystone type, which can stand against heavy loads, and the barrel face on the ring fits well to the cylinder wall.

The second ring (2) is an undercut type, which effectively prevents the oil from being carried up.

The oil ring (3) has chamfered contact faces and an expander ring, which increase the pressure of the oil ring against the cylinder wall.

Several grooves are cut on the topland to help heat dissipate and to prevent scuffing.

- (1) Top Ring
- (2) Second Ring
- (3) Oil Ring

[5] CONNECTING ROD

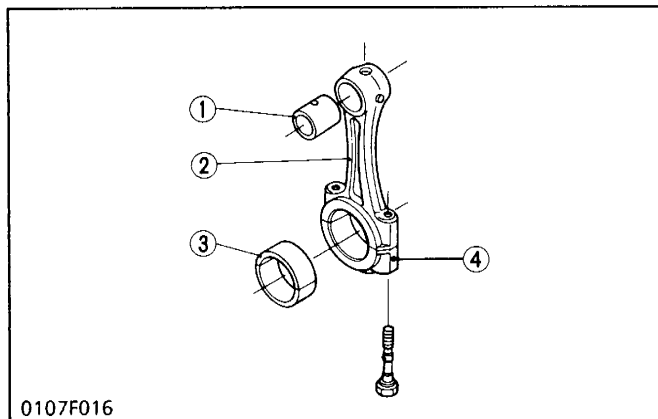

Connecting rod (2) is used to connect the piston with the crankshaft. The big end of the connecting rod has a crank pin bearing (3) (split type) and the small end has a small end bushing (1) (solid type).

- (1) Small End Bushing
- (2) Connecting Rod
- (3) Crank pin Bearing
- (4) Connecting Rod Cap

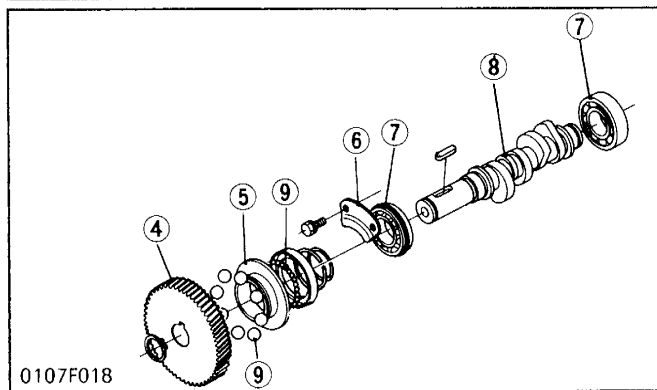
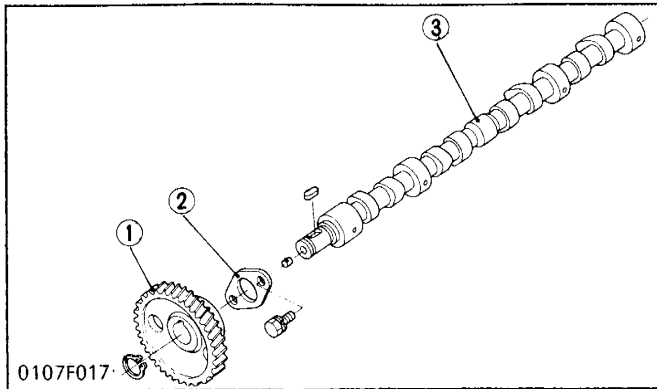
[6] CAMSHAFT

The camshaft (3) is made of special cast iron and the journal and cam sections are chilled to resist wear. The journal sections are force-lubricated. The fuel camshaft (8) controls the reciprocating movement of the injection pump, and is equipped with a ball to control the governor. The fuel camshaft is made of carbon steel and the cam sections are quenched and tempered to provide greater wear resistance.

- (1) Cam Gear
- (2) Camshaft Stopper
- (3) Camshaft
- (4) Injection Pump Gear
- (5) Governor Sleeve
- (6) Fuel Camshaft Stopper
- (7) Ball Bearing
- (8) Fuel Camshaft
- (9) Steel Ball

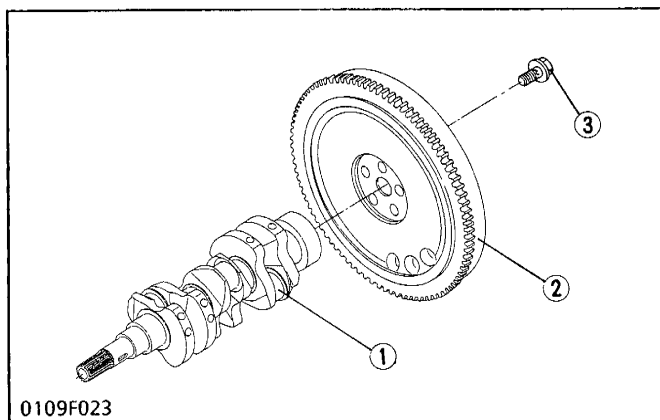
[7] FLYWHEEL

The flywheel stores the rotating force in the combustion stroke as inertial energy, reduces crankshaft rotating speed fluctuation and maintains the smooth rotating conditions.

The flywheel periphery is inscribed with the marks showing fuel injection timing angle lines and top dead center mark TC.

The flywheel has gear teeth around its outer rim, which mesh with the drive pinion of the starter.

- (1) Crankshaft
- (2) Flywheel
- (3) Flywheel Screw

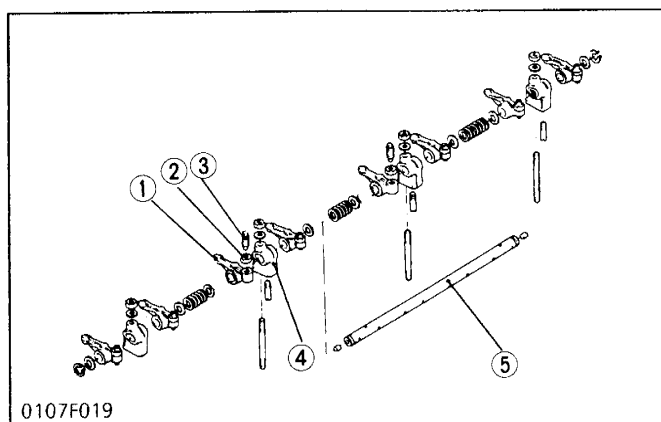
[8] ROCKER ARM

The rocker arm assembly includes the rocker arms (1), rocker arm brackets (4) and rocker arm shaft (5) and converts the reciprocating movement of the push rods to an open/close movement of the inlet and exhaust valves.

Lubricating oil is pressurized through the bracket to the rocker arm shaft, which serves as a fulcrum so that the rocker arm bearing and the entire system are lubricated sufficiently.

- (1) Rocker Arm
- (2) Lock Nut
- (3) Adjusting Screw
- (4) Rocker Arm Bracket
- (5) Rocker Arm Shaft

2 LUBRICATING SYSTEM

[1] GENERAL

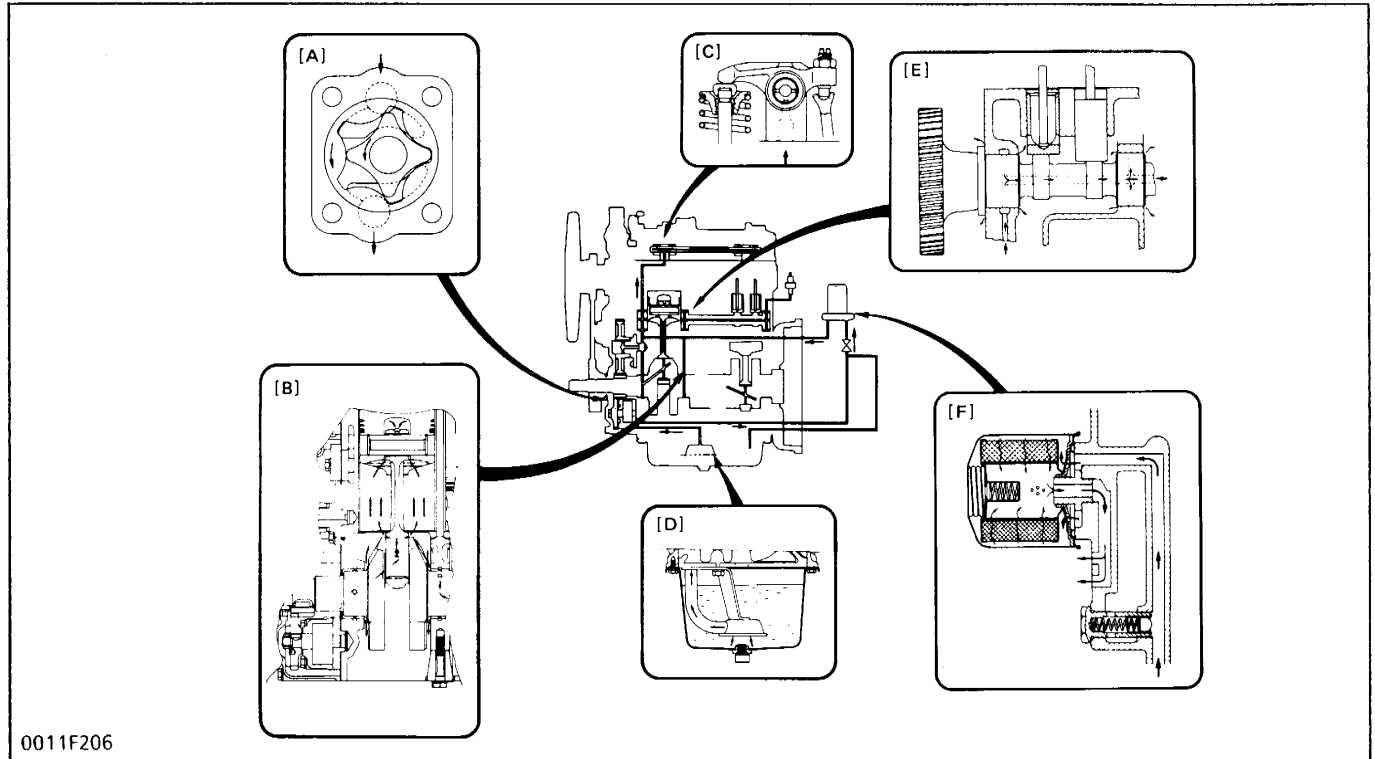

This engine lubricating consists of oil strainer, oil pump, relief valve, oil filter cartridge and oil switch. The oil pump sucks lubricating oil from the oil pan through the oil strainer and the oil flows down to the filter cartridge, where it is further filtered. Then the oil is forced to crankshaft, connecting rods, idle gear, camshaft and rocker arm shaft to lubricate each part. Some part of oil, splashed by the crankshaft or leaking and dropping from gaps of each part, lubricates these parts: pistons, cylinders, small ends of connecting rods, tappets, pushrods, inlet and exhaust valves and timing gears.

- [A] Oil Pump
- [B] Piston
- [C] Rocker Arm and Rocker Arm Shaft
- [D] Oil Strainer
- [E] Camshaft
- [F] Oil Filter Cartridge and Relief Valve

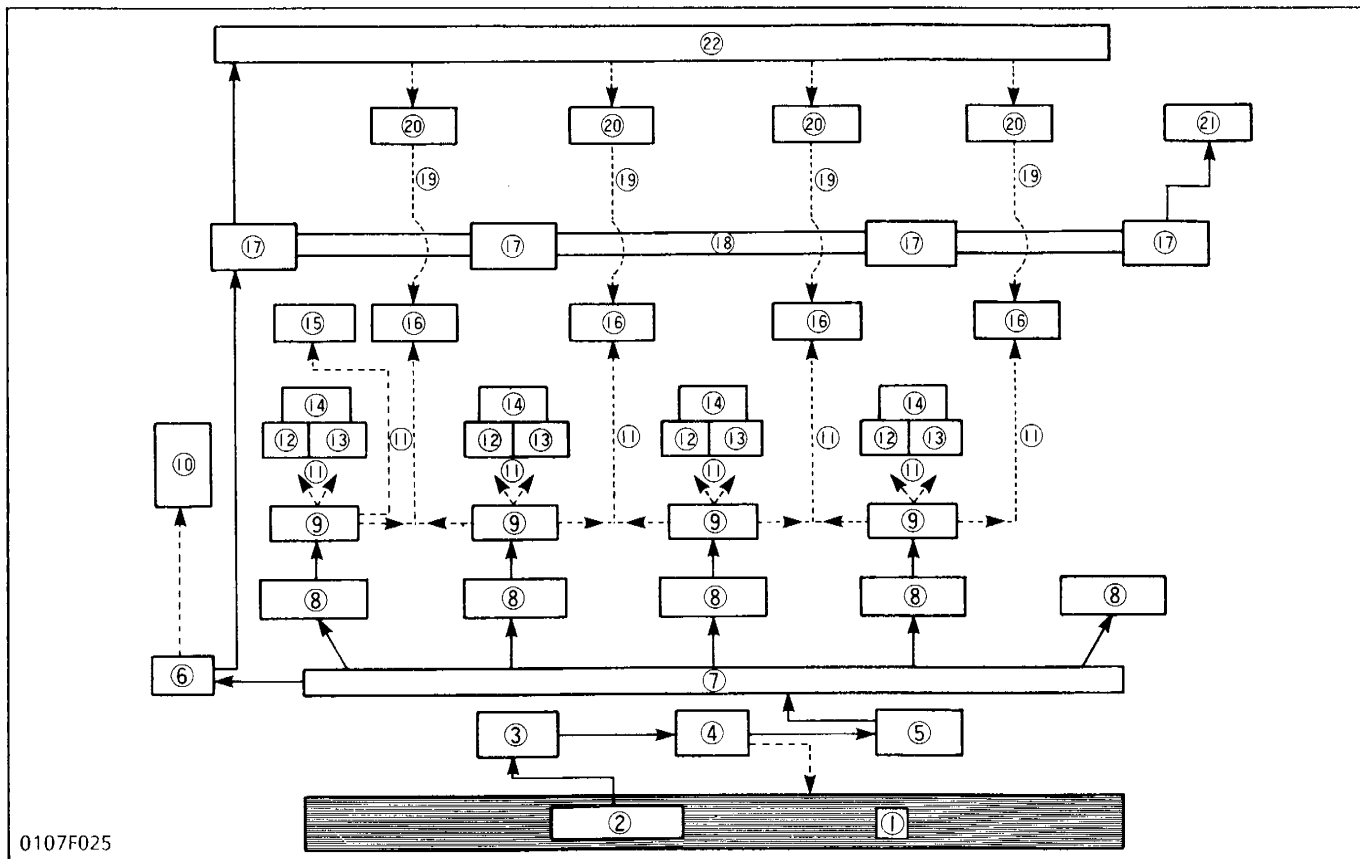

Engine Oil Flow

- | | | |
|--------------------------|--------------------|-----------------------|
| (1) Oil Pan | (9) Big End | (17) Camshaft Bearing |
| (2) Oil Strainer | (10) Timing Gear | (18) Camshaft |
| (3) Oil Pump | (11) Splash | (19) Drain |
| (4) Relief Valve | (12) Bore | (20) Rocker Arm |
| (5) Oil Filter Cartridge | (13) Small End | (21) Oil Switch |
| (6) Idle Gear | (14) Piston | (22) Rocker Arm Shaft |
| (7) Main Oil Gallery | (15) Fuel Camshaft | |
| (8) Main Bearing | (16) Tappets | |

[2] OIL PUMP

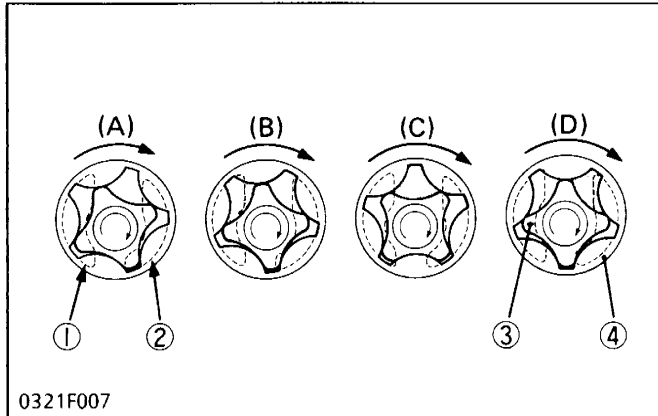

The oil pump in this engine is a trochoid pump. Inside the pump body, the 4 lobe inner rotor (3) is eccentrically engaged with the 5 lobe outer rotor (4). The inner rotor is driven by the crankshaft via gears, which in turn rotate the outer rotor.

When the inner rotor rotates, the outer rotor also rotates in the same direction.

The two rotors have differences in lobe number and center, which generates space between lobes as shown in the figure.

At position (A), there is little space between lobes in the inlet port. As the rotor rotates towards position (B), the space between the lobes becomes larger, creating a negative pressure which sucks in oil.

Outside the inlet port, as shown in position (C), the space between the lobes becomes gradually smaller, and oil pressure increases. At position (D), oil is discharged from the outlet port.

- (1) Inlet
- (2) Outlet
- (3) Inner Rotor
- (4) Outer Rotor

[3] RELIEF VALVE

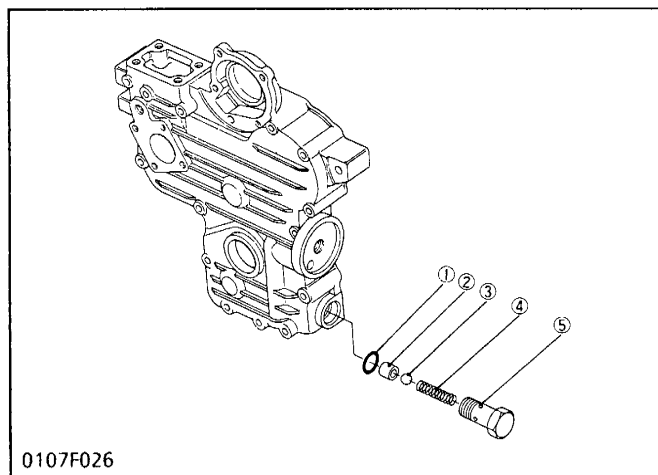

The relief valve prevents damage to the lubricating system due to high oil pressure. This relief valve is a ball type direct acting relief valve, and is best suited for low pressures.

When oil pressure exceeds the upper limit, the ball (3) is pushed back by the pressure oil and the oil escapes.

- (1) O-ring
- (2) Valve Seat
- (3) Steel Ball
- (4) Spring
- (5) Relief Valve Body

[4] OIL FILTER CARTRIDGE

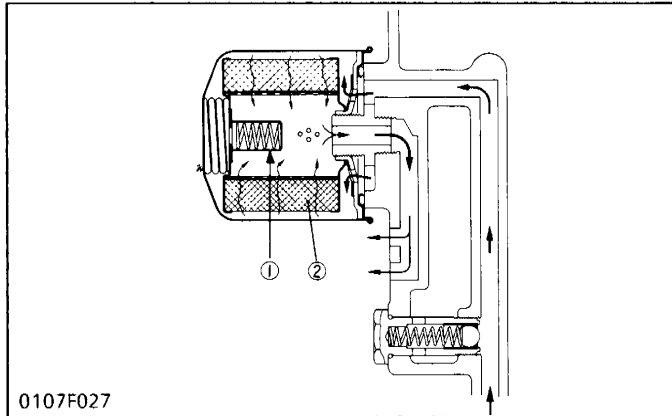

Impurities in engine oil can cause to wear and seize components as well as impairing the physical and chemical properties of the oil itself. Impurities contained in force-fed engine oil are absorbed on the filter paper for removal as they pass through the filter element (2).

When the filter element is clogged and the oil pressure in inlet line builds up by 98 kPa (1.0 kgf/cm², 14 psi) more than the outlet line, the bypass valve (1) opens and the oil flows from inlet to outlet bypassing the filter element.

- (1) Bypass Valve
- (2) Filter Element

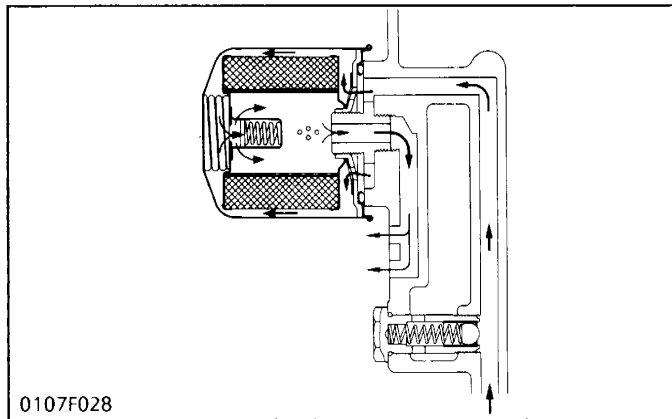

[5] OIL PRESSURE SWITCH

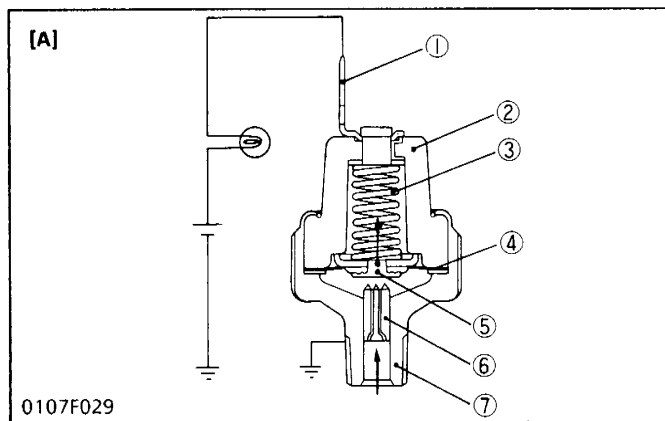

The oil pressure switch is mounted on the cylinder-block, to warn the operator that the lubricating oil pressure is poor.

If the oil pressure falls below 49kPa (0.5 kgf/cm², 7 psi), the oil warning lamp will light up, warning the operator. In this case, stop the engine immediately and check the cause of pressure drop.

- [A] At Proper Oil Pressure
- [B] At Oil Pressures of 49 kPa (0.5 kgf/cm², 7 psi) or Less

- (1) Terminal
- (2) Insulator
- (3) Spring
- (4) Diaphragm
- (5) Contact Rivet
- (6) Contact
- (7) Oil Switch Body

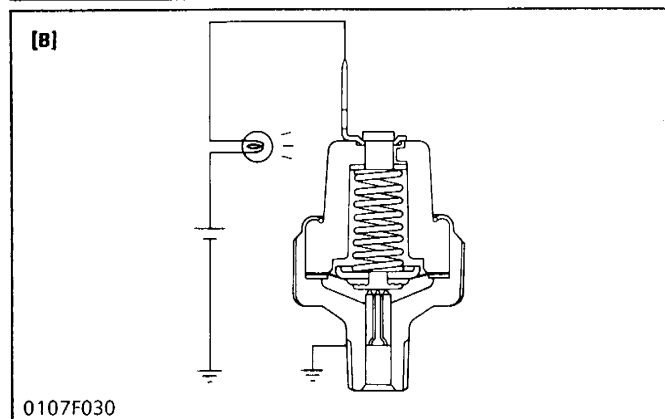

3 COOLING SYSTEM

[1] GENERAL

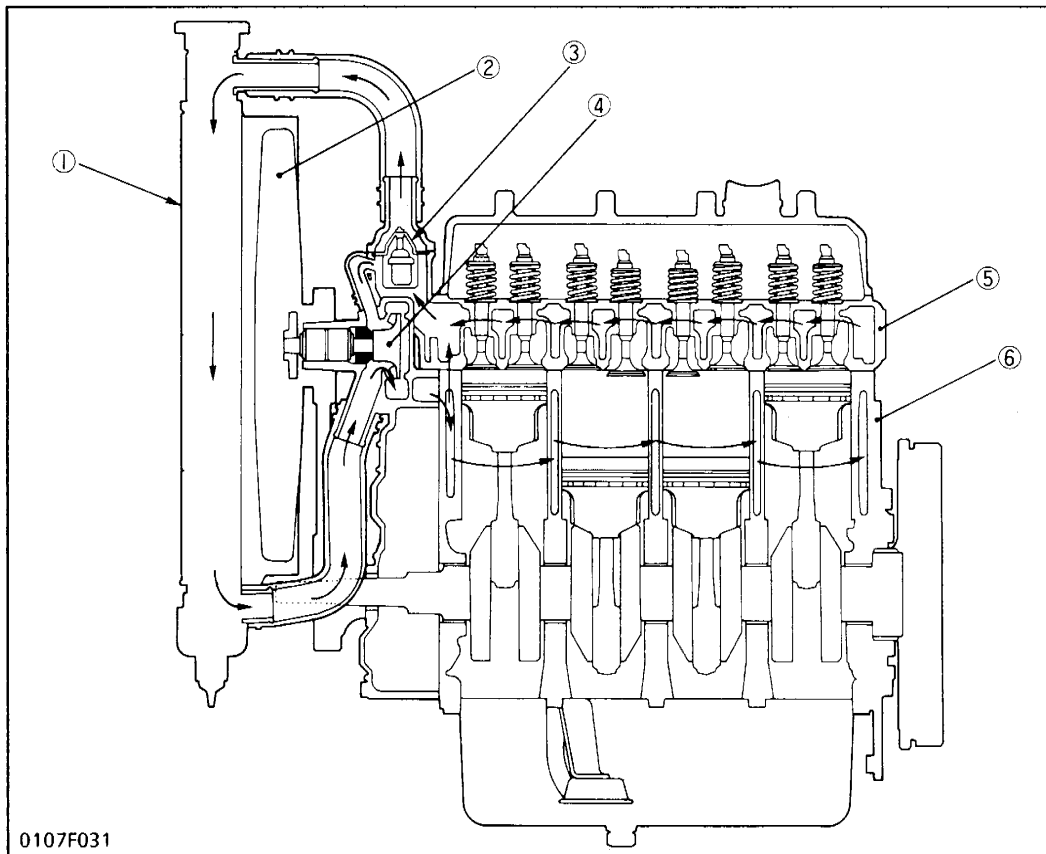

- (1) Radiator
- (2) Suction Fan
- (3) Thermostat
- (4) Water Pump
- (5) Cylinder Head
- (6) Cylinder Block

0107F031

The cooling system consists of a radiator (1) (not included in the basic engine), centrifugal water pump (4), suction fan (2) and thermostat (3).

The coolant is cooled through the radiator core, and the fan set behind the radiator pulls cooling air through the core to improve cooling.

The water pump sucks the cooled coolant, forces it into the cylinder block and draws out the hot coolant.

Then the cooling is repeated. Furthermore, to control temperature of coolant, a thermostat is provided in the system. When the thermostat opens, the coolant moves directly to radiator, but when it closes, the coolant moves toward the water pump through the bypass between thermostat and water pump. The opening temperature of thermostat is approx. 82°C (180°F).

[2] WATER PUMP

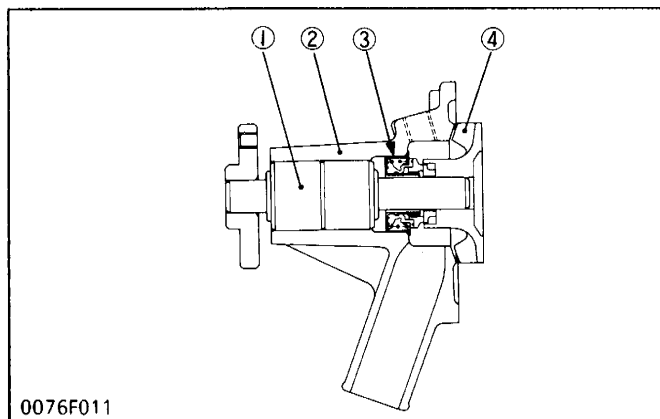

0076F011

The water pump is driven by the crankshaft via a V-belt. Coolant cooled in the radiator is sucked into the water pump from its lower portion and is sent from the center of the water pump impeller (4) radially outward into the water jacket in the crankcase.

- (1) Bearing Unit
- (2) Water Pump Body
- (3) Mechanical Seal
- (4) Water Pump Impeller

[3] THERMOSTAT

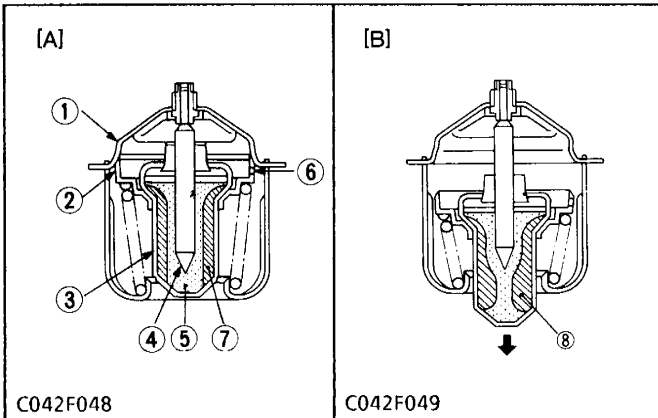

- (1) Seat
- (2) Valve
- (3) Pellet
- (4) Spindle
- (5) Synthetic Rubber
- (6) Leak Hole
- (7) Wax (solid)
- (8) Wax (liquid)

The thermostat maintains the coolant at correct temperature. KUBOTA's engine uses a wax pellet type thermostat. Wax is enclosed in the pellet. The wax is solid at low temperatures, but turns liquid at high temperatures, expands and opens the valve.

- (A) At low temperatures (lower than 82°C (180°F)).
As the thermostat is closed, coolant circulates in the engine through the coolant return pipe without running to the radiator. Air in the water jacket escapes to the radiator side through leak hole (6) of the thermostat.
- (B) At high temperatures (higher than 82°C (180°F)).
When the temperature of coolant exceeds 82°C (180°F), wax in the pellet turns liquid and expands. Because the spindle (4) is fixed, the pellet (3) is lowered, the valve (2) is separated from the seat (1), and then coolant is sent to the radiator.

[4] RADIATOR (not included in the basic engine)

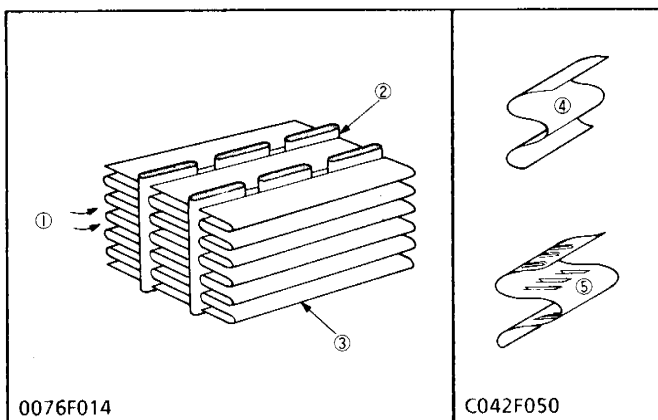

The radiator core consists of coolant carrying tubes and fins (3) at a right angle to the tubes (2). Heat of hot coolant in the tubes is radiated from the tube walls and fins. KUBOTA's engine uses corrugated fin type core which has a light weight and high heat transfer rate. Clogging is minimized by the louverless corrugated fins.

- (1) Cooling Air
- (2) Tube
- (3) Fin
- (4) Louverless Corrugated Fin
- (5) Louvered Corrugated Fin

[5] RADIATOR CAP

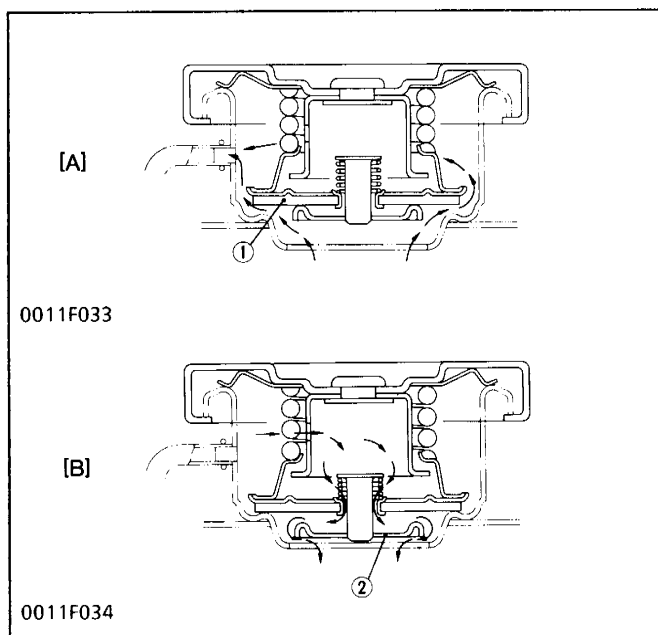

The radiator cap is for sustaining the internal pressure of the cooling system at the specified level 88 kPa (0.9 kgf/cm², 13 psi) when the engine is in operation. The cap consists of a pressure valve (1) a vacuum valve (2), valve springs, gasket, etc.

Coolant is pressurized by thermal expansion of steam, and as its boiling temperature rises, generation of air bubbles will be suppressed. (Air bubbles in coolant lowers the cooling effect.)

- [A] When radiator internal pressure is high
- [B] When radiator internal pressure is negative
- (1) Pressure Valve
- (2) Vacuum Valve

4 INTAKE/EXHAUST SYSTEM

[1] AIR CLEANER (not included in the basic engine)

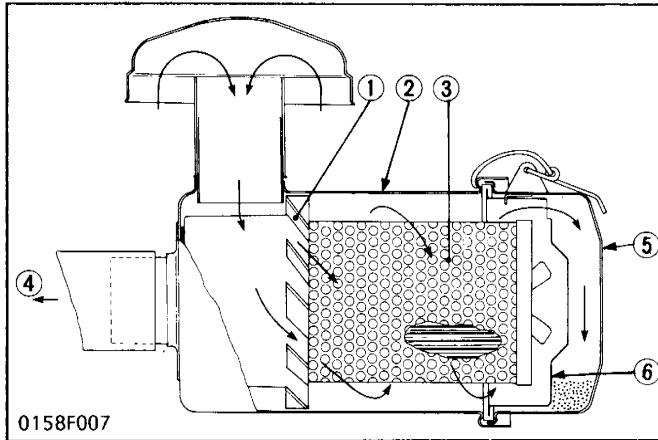

The air cleaner is a dry-cyclone type for easy maintenance. Sucked air is caused to flow in a whirling way with fin (1). As a result, heavier dust particles circulate around the circumference and enter the holes in the baffle cover (6) and accumulate in the dust cup (5). Minute dust, while circulating in the air flow, is absorbed by the element (3) and thus prevented from entering the engine.

- (1) Fin
- (2) Air Cleaner Body
- (3) Air Filter Element
- (4) To Cylinder
- (5) Dust Cup
- (6) Baffle Cover

[2] MUFFLER (not included in the basic engine)

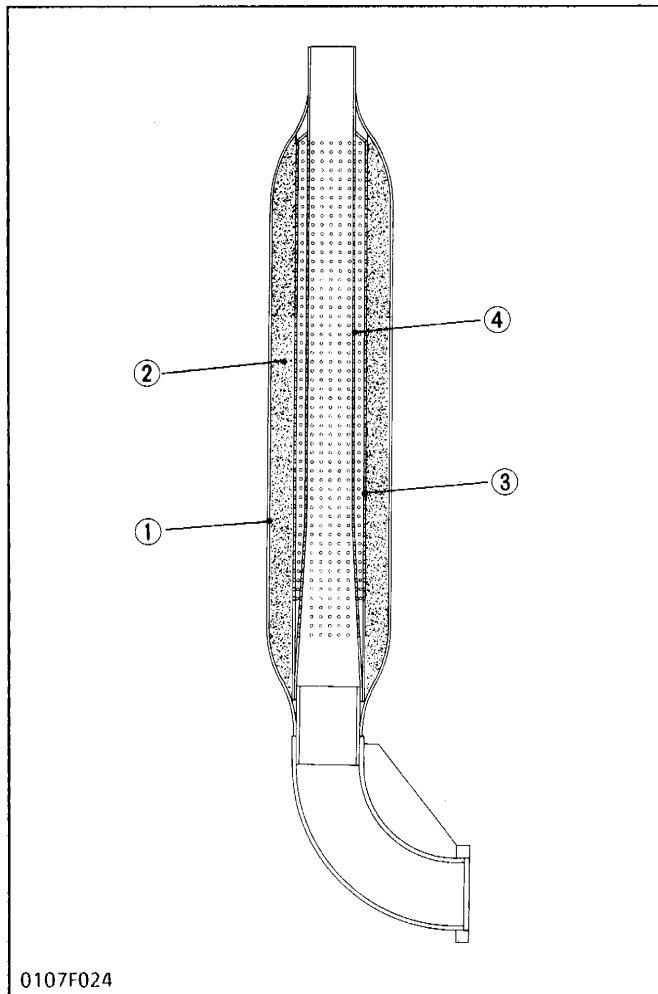

High temperature and high pressure exhaust gas is intermittently discharged by fuel combustion generating pressure waves inside the exhaust pipe which will result in noise.

The muffler is used to reduce this noise.

This muffler consists of a perforated inner tube (4) and outer tube (3), glass wool (2), main body (1), etc. The glass wool placed between the outer tube and main body, absorbs the exhaust noise of higher frequency.

- (1) Main Body
- (2) Glass Wool
- (3) Outer Tube
- (4) Inner Tube

5 FUEL SYSTEM

[1] GENERAL

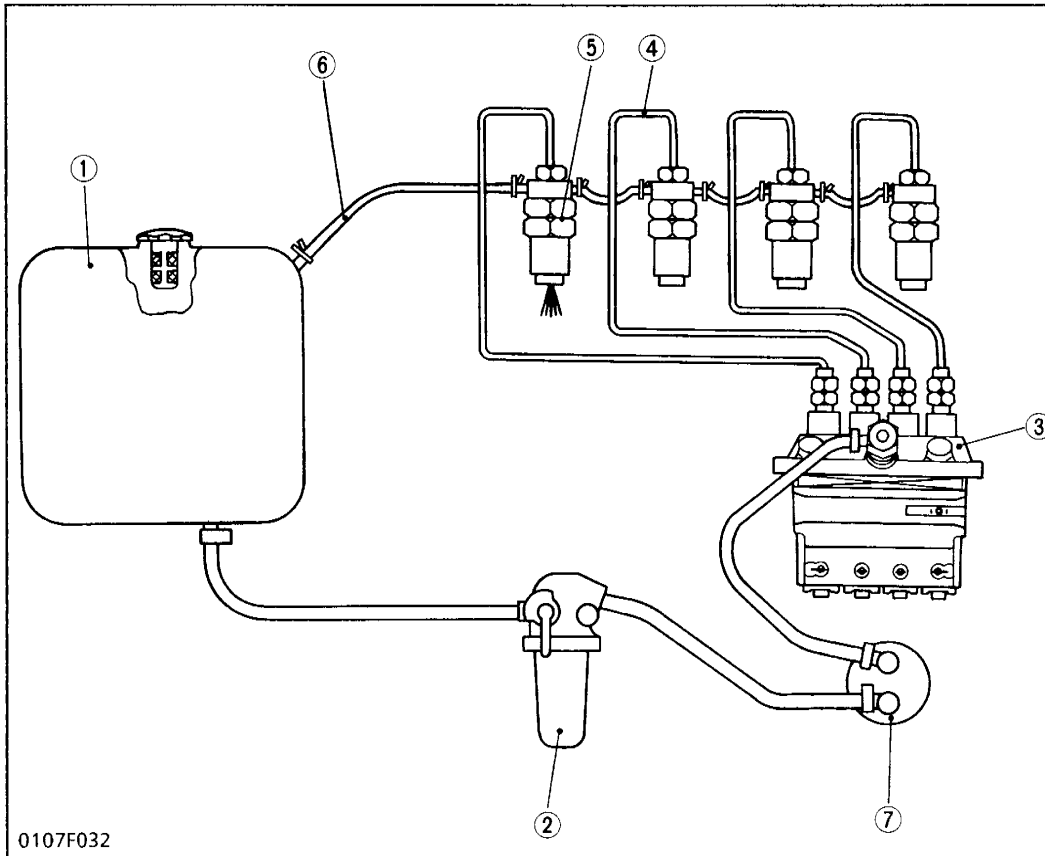

- (1) Fuel Tank
- (2) Fuel Filter
- (3) Injection Pump
- (4) Injection Pipe
- (5) Injection Nozzle
- (6) Fuel Overflow Pipe
- (7) Fuel Lift Pump

Fuel from the fuel tank (1) passes through the fuel filter (2), and then enters the injection pump (3) after impurities such as dirt, water, etc. are removed.

The fuel pressurized by the injection pump to the opening pressure (13.73 to 14.71 MPa, 140 to 150 kgf/cm², 1991 to 2062 psi), of the injection nozzle (5) is injected into the combustion chamber.

Part of the fuel fed to the injection nozzle (5) lubricates the moving parts of the plunger inside the nozzle, then returns to the fuel tank through the fuel overflow pipe (6) from the upper part of the nozzle holder.

[2] INJECTION PUMP

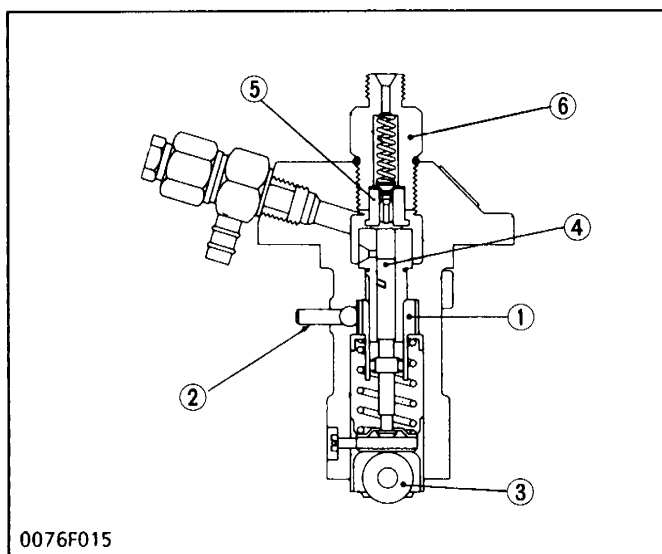

A Bosch K type mini pump is used for the injection pump. It is small, lightweight and easy to handle.

The plunger (4) with a right-hand lead reciprocates via the tappet roller (3) by means of the camshaft fuel cam, causing the fuel to be delivered into the injection nozzle.

- (1) Control Sleeve
- (2) Control Rack
- (3) Tappet Roller
- (4) Plunger
- (5) Delivery Valve
- (6) Delivery Valve Holder

(1) Pump Element

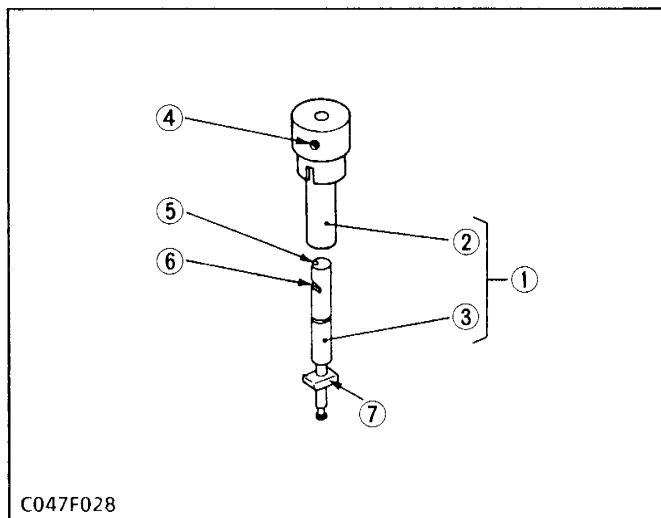

The pump element (1) is consist of the plunger (3) and cylinder (2).

The sliding surfaces are super-precision machined to maintain injection pressure at engine low speeds. Since the driving face (7) fits in the control sleeve, the plunger (3) is rotated by the movement of the control rack to increase or decrease of fuel delivery.

As described above, the plunger (3) is machined to have the slot (5) and the control groove (6).

- (1) Pump Element
- (2) Cylinder
- (3) Plunger
- (4) Feed Hole
- (5) Slot
- (6) Control Groove
- (7) Driving Face

(2) Delivery Valve

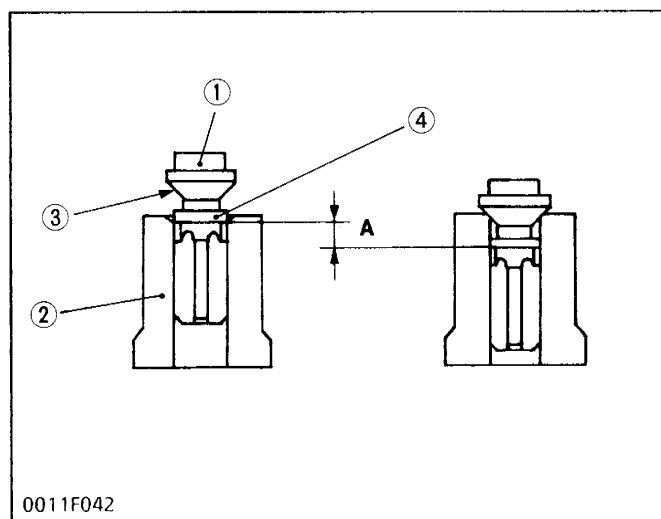

The delivery valve consists of the delivery valve (1) and delivery valve seat (2).

The delivery valve performs the following functions.

1. Reverse flow preventing function

If the fuel flow reverse from the injection nozzle side when the plunger lowers, the time lag between the next delivery start and the nozzle injection start increases. To avoid this, the delivery chamber to injection pipe interruption by delivery valve (1) prevents this reverse flow, thus keeping fuel always filled in the nozzle and pipe.

2. Suck-back function

After completing the fuel delivery, the delivery valve lowers, and the relief plunger (4) end contacts the delivery valve seat (2). The valve further lowers until its seat surface (3) seats firmly the delivery valve seat. During this time, the amount of fuel corresponding to (A) is sucked back from inside the injection pipe, the pressure inside the pipe is reduced, thus leading to an improved injection shut off and preventing after leakage dribbling.

- (1) Delivery Valve
- (2) Delivery Valve Seat
- (3) Seat Surface
- (4) Relief Plunger

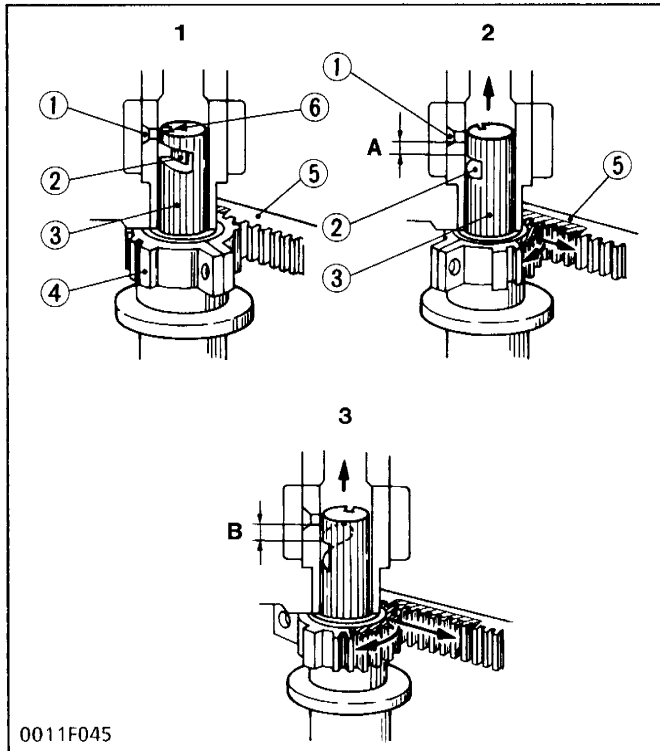
(3) Injection Control

0011F045

1. No fuel delivery Engine stop

When the control rack (5) is set at the engine stop position, the plunger does not force fuel and no fuel is delivered since the feed hole (1) aligns with the slot (6) in the plunger (3).

2. Partial fuel delivery

When the plunger (3) is rotated by the control rack (5) in the direction of arrow, the fuel is delivered to the injection nozzle.

The amount of fuel corresponds to the effective stroke (A) from closing the feed hole (1) by the plunger head to contact of the control groove (2) with the feed hole.

3. Maximum fuel delivery

When the control rack is moved to the extreme end in the direction of the arrow, the effective stroke (B) of the plunger is at its maximum, thus the maximum fuel delivery occurs.

- (1) Feed Hole
- (2) Control Groove
- (3) Plunger
- (4) Control Sleeve
- (5) Control Rack
- (6) Slot

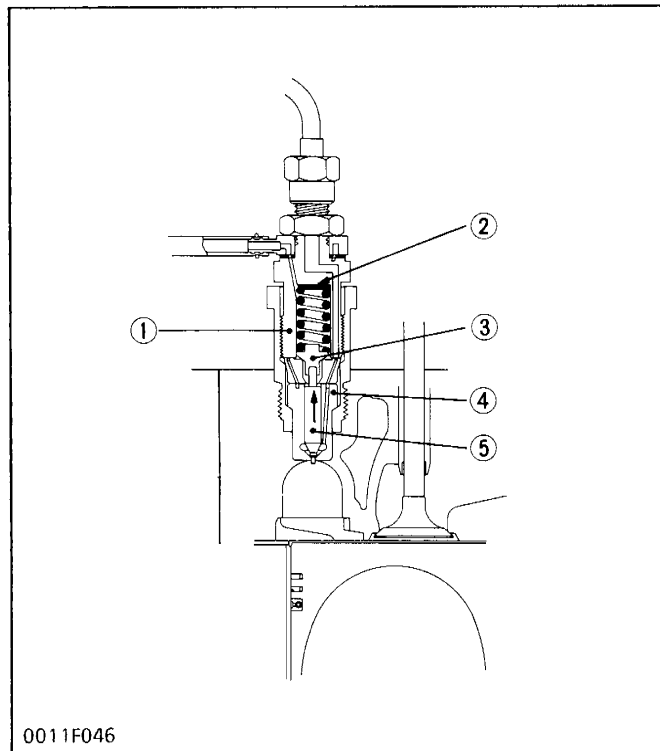
[3] INJECTION NOZZLE

0011F046

This nozzle is throttle-type. The needle valve (5) is pushed against the nozzle body (4) by the nozzle spring via the push rod (3). Fuel pressurized by the injection pump pushes the needle valve up and then is injected into the sub-combustion chamber.

Excessive flow passes from nozzle holder center through the eye joint and the fuel overflow pipe to the fuel tank.

The injection pressure is 13.73 to 14.71 MPa (140 to 150 kgf/cm², 1991 to 2133 psi), and is adjusted with adjusting washers (2).

- (1) Nozzle Holder Body
- (2) Adjusting Washer
- (3) Push Rod
- (4) Nozzle Body
- (5) Needle Valve

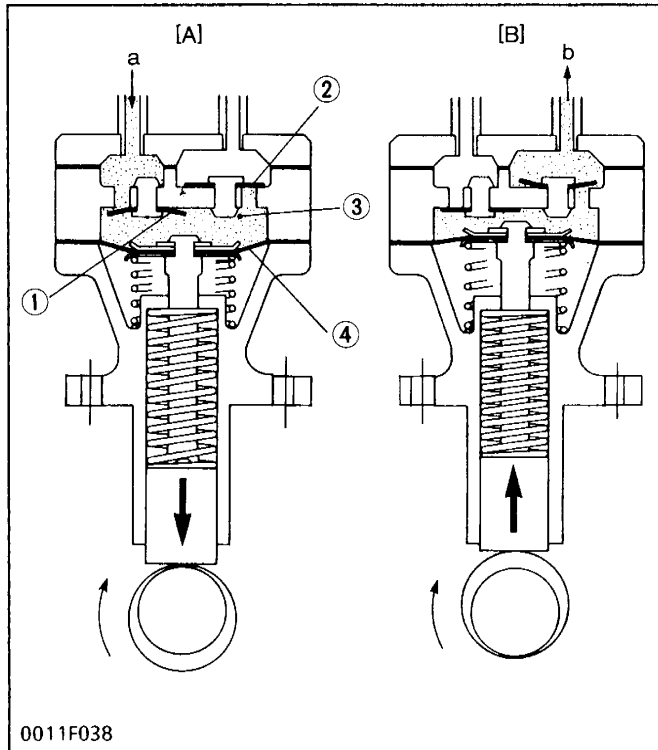
[4] FUEL LIFT PUMP

Filtered fuel is fed to the injection pump by the fuel lift pump. The fuel lift pump operates as shown in the figure. Power is applied to the tappet by an eccentric movement on the fuel camshaft. As the fuel camshaft rotates, the eccentric movement causes the tappet to move up and down. The tappet is linked to a flexible diaphragm (4) via the pull rod.

When the diaphragm is pulled down, a low vacuum or low pressure area is created above the diaphragm. This causes atmospheric pressure in the fuel tank to force fuel into the fuel lift pump. The inlet valve (1) opens to admit fuel into the chamber (3).

When the diaphragm is pushed up, pressure is created in the area above the diaphragm. This pressure closes the inlet valve and opens the outlet valve (2), forcing fuel from the pump through the fuel pipe to the injection pump.

- [A] Inlet Stroke**
[B] Discharge Stroke
(a) From Fuel Filter
(b) To Injection Pump
- (1) Inlet Valve
 (2) Outlet Valve
 (3) Chamber
 (4) Diaphragm

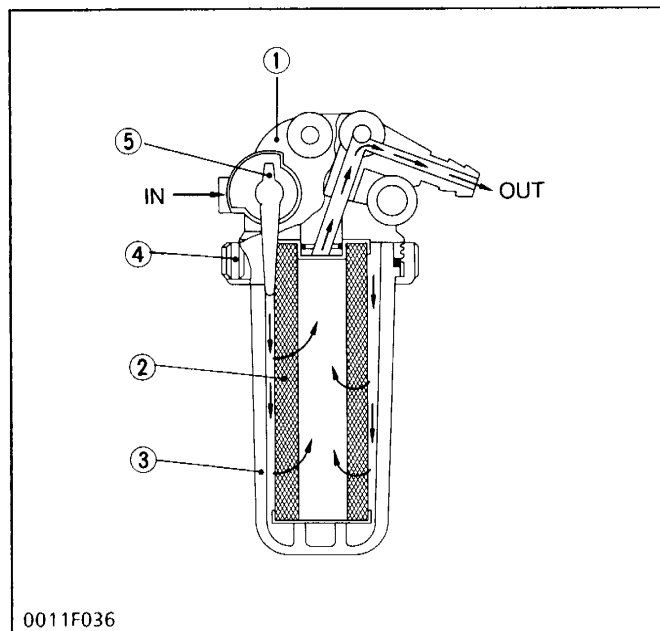
[5] FUEL FILTER (not included in the basic model)

Each moving part of the injection pump and nozzle is extremely precision machined, and clearances of their sliding parts are extremely small. Fuel itself serves as lubricating oil. For this reason, it is extremely important to completely remove water and dirt contained in fuel.

This fuel filter, which uses very fine filter paper, serves to separate and filter dirt in fuel and water accumulated in the tank.

Air vent plug is fitted to the cock body. Before starting or after disassembling and reassembling, loosen this plug and bleed the air in the fuel system.

- (1) Cock Body
 (2) Filter Element
 (3) Filter Cup
 (4) Retaining Ring
 (5) Fuel Cock

[6] GOVERNOR

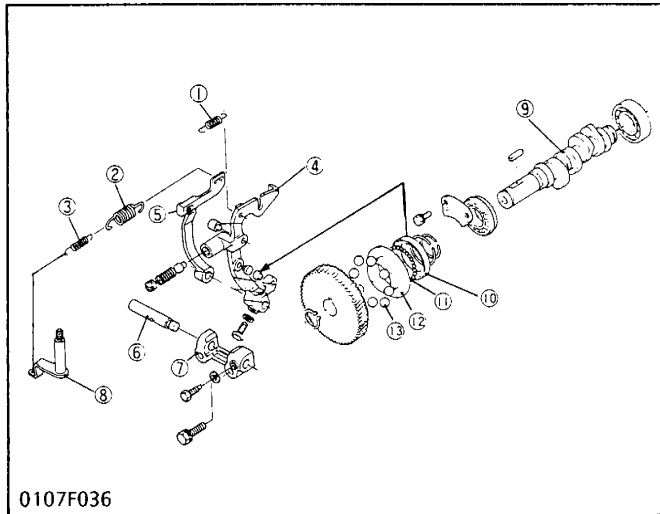

The governor serves to keep engine speed constant by automatically adjusting the amount of fuel supplied to the engine according to changes in the load. This engine employs an all-speed governor which controls the centrifugal force of the steel ball (13) weight, produced by rotation of the fuel camshaft (9), and the tension of the governor spring 1 (2) and 2 (3) are balanced.

- | | |
|-----------------------|-------------------------|
| (1) Start Spring | (8) Governor Lever |
| (2) Governor Spring 1 | (9) Fuel Camshaft |
| (3) Governor Spring 2 | (10) Governor Ball Case |
| (4) Fork Lever 1 | (11) Steel Ball |
| (5) Fork Lever 2 | (12) Governor Sleeve |
| (6) Fork Lever Shaft | (13) Steel Ball |
| (7) Fork Lever Holder | |

■ At start

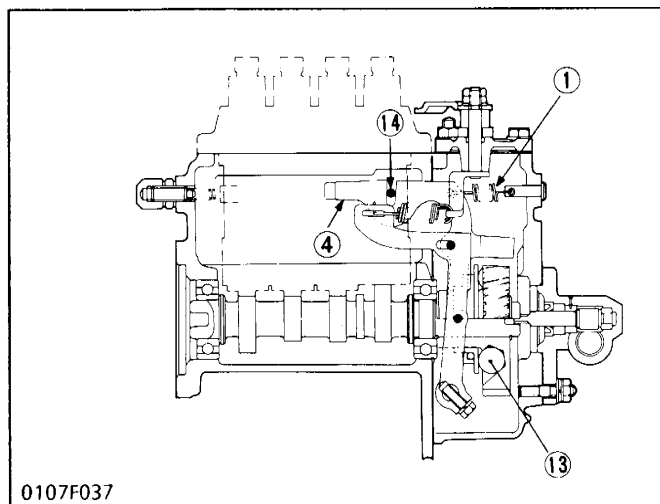

Since the steel balls (13) have no centrifugal force, a fork lever 1 (4) is pulled to the right by the starter spring (1). Accordingly, the control rack (14) moves to the maximum injection position to assure easy starting.

- (14) Control Rack

■ At idling

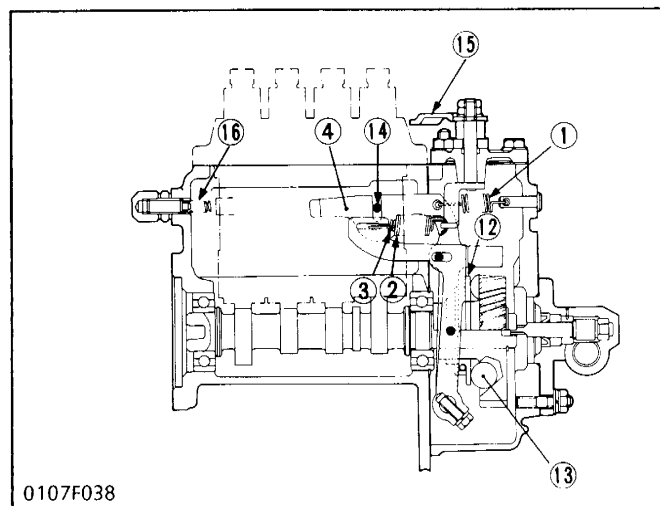

When the speed control lever (15) is set at the idling position after the engine starts, the governor spring 1 (2) does not work at all and the governor spring 2 (3) does only act slightly. The governor sleeve (12) is pushed leftward by a centrifugal force of steel balls (13).

Therefore, the fork lever 1 (4) and control rack (14) are moved to the left by the governor sleeve and then the idling limit spring (16) is compressed by the control rack. As a result, the control rack is kept at a position where a centrifugal force of steel balls and forces start spring (1), governor spring 2 and idling limit spring are balanced, providing stable idling.

- (15) Speed Control Lever
(16) Idling Limit Spring

■ At high speed running with overload

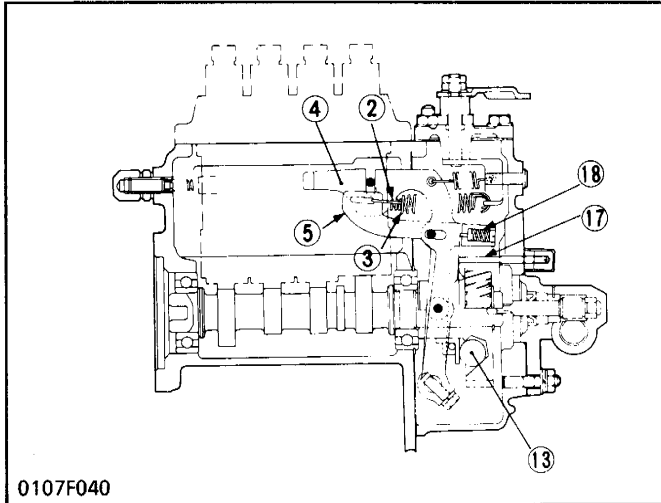

When an overload is applied to the engine running at a high speed, the centrifugal force of steel balls (13) becomes small as the engine speed is dropped, and fork lever 2 (5) is pulled to the right by the governor springs 1 (2) and 2 (3), increasing fuel injection. Though, fork lever 2 becomes ineffective in increasing fuel injection when it is stopped by the adjusting bolt (17).

After that, when the force of torque spring (18) becomes greater than the centrifugal force of the steel ball, fork lever 1 (4) moves rightward to increase fuel injection, causing the engine to run continuously at a high torque.

- (17) Adjusting Bolt
- (18) Torque Spring

■ To stop engine

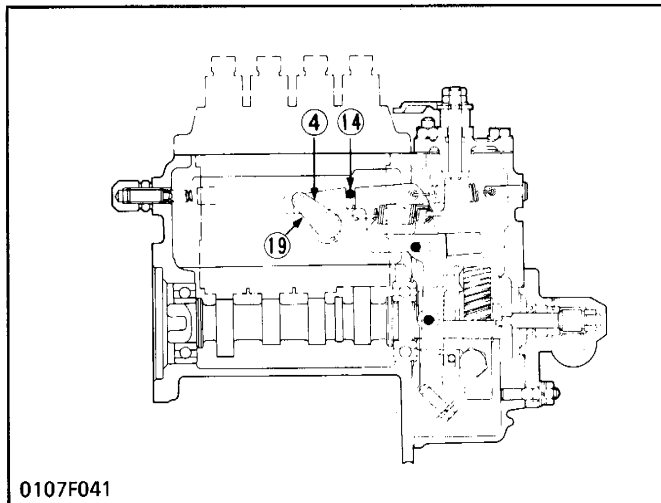

When the stop lever (19) is moved to STOP position, fork lever 1 (4) is moved leftward and the control rack (14) is moved to the non-injection position, stopping the engine.

- (19) Stop Lever

6 ELECTRICAL SYSTEM

[1] GENERAL

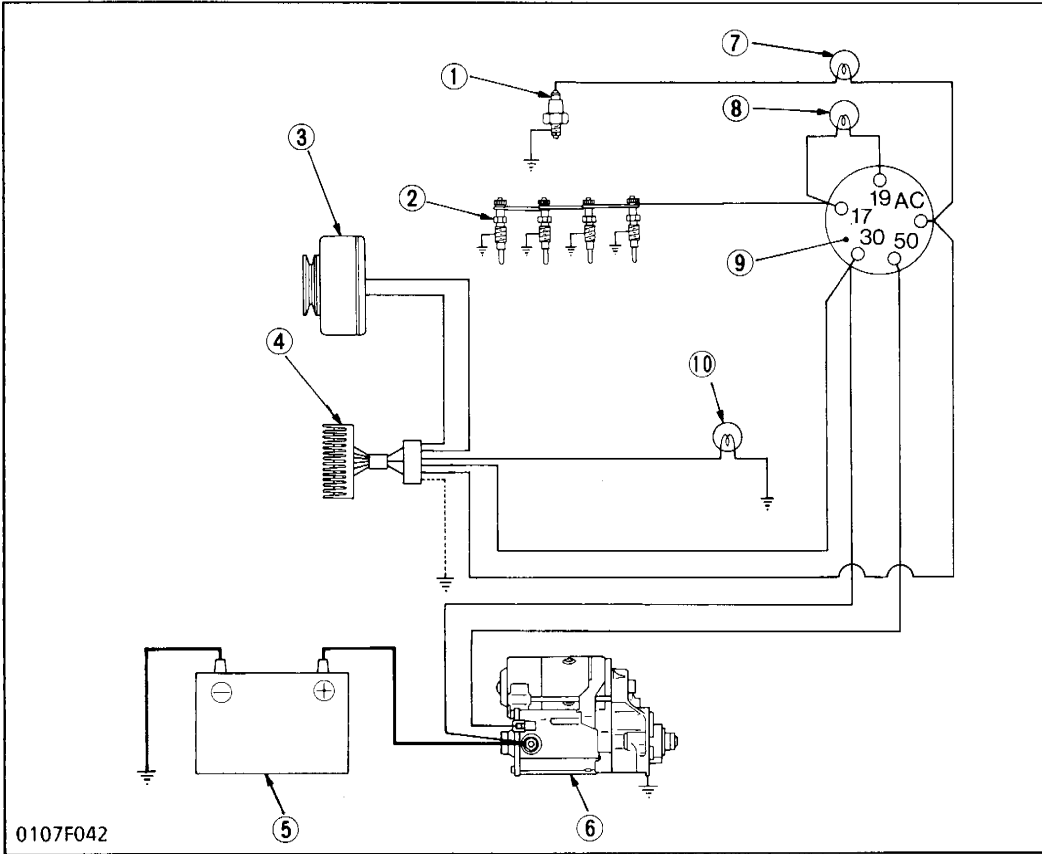

- (1) Oil Switch
- (2) Glow Plug
- (3) Alternator
- (4) Regulator
- (5) Battery
- (6) Starter
- (7) Oil Lamp
- (8) Glow Plug Indicator
- (9) Key Switch
- (10) Charge Lamp

*(5), (7), (8), (9) and (10) are not included in the basic engine.

0107F042

The electrical system of the engine consists of a starting system (including a starter, glow plugs, etc.), a charging system (including an alternator, regulator, etc.), a battery and an oil switch.

[2] CHARGING SYSTEM

(1) Alternator

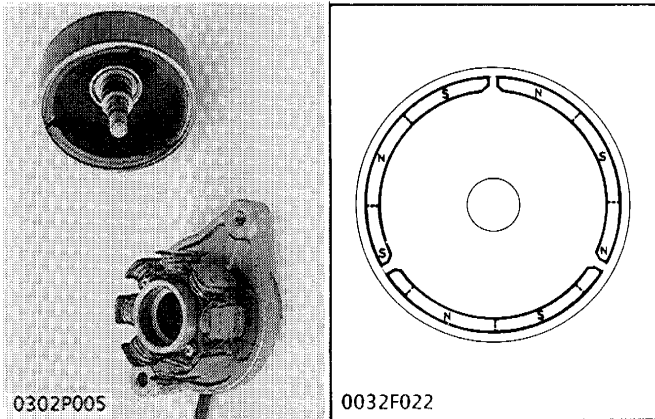

This alternator is an 8 pole rotating magnet type generator. It is simple in construction, consisting of a stator and rotor.

The rotor is made up of eight permanent magnet pole pieces assembled on a shaft and rotates on the center of the stator around which eight electromagnetic coils are provided. This alternator produces higher voltage in slow speed rotation, and charges electric current to the battery during engine idling.

Rotation direction	Clockwise (as seen from pulley side)
Speed in normal use	1600 to 5600 rpm
Charging performance	Over 14A at 5200 rpm
Charge starting speed	Over 1800 rpm

(2) Regulator

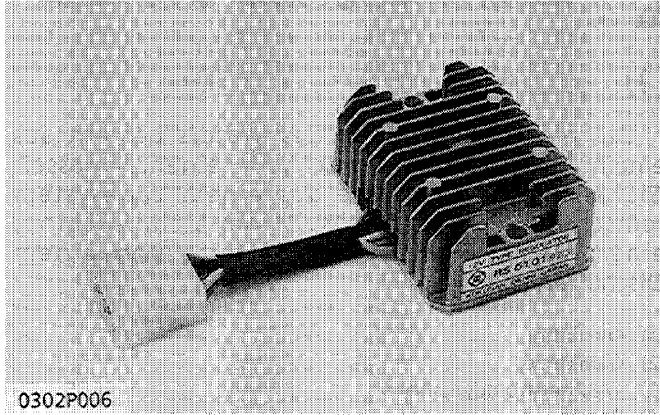

A regulator has two functions:

1. When the battery voltage is low, it turns the SCR on to form a charging circuit to the battery.
2. During charging, it turns the charging lamp off.

■ When the key switch is turned "ON"

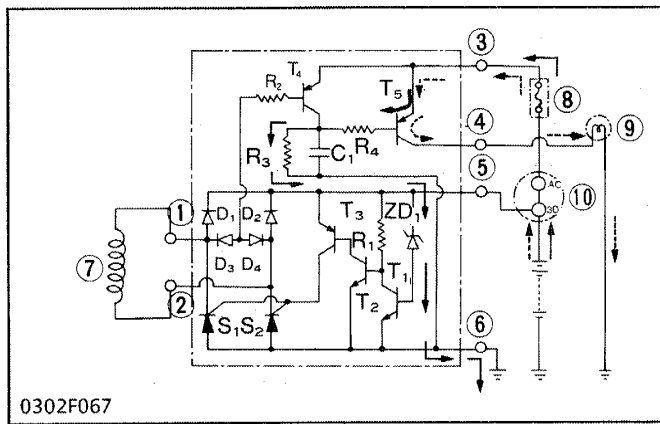

When the key switch is turned on, current (→) flows from the base of transistor T5 to resistor R4, resistor R3 and to ground, turning transistor T5 on. Then, the current (↔) flows to the charge lamp to light.

- (1) Light Blue (To alternator)
- (2) Light Blue (To alternator)
- (3) Yellow (To key switch AC terminal)
- (4) Green (To charge lamp)
- (5) Red (To key switch terminal No.30)
- (6) Black (To ground)
- (7) Alternator
- (8) Fuse
- (9) Charge Lamp
- (10) Key Switch

■ When the engine starts

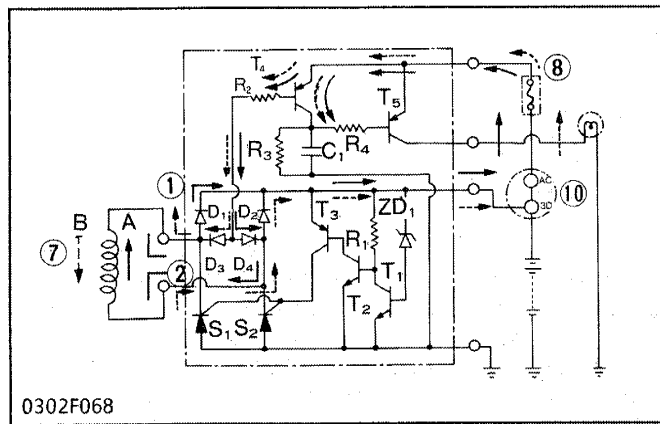

When the engine starts and a generated voltage in the alternator causes a current in ↑ (A) direction, the current flows as follows:

Diode D1 → Key Switch → Transistor T4 → Resistor R2 → Diode D4 → Alternator.

With a current in ↓ (B) direction, a current flows as follows:

Diode D2 → Key Switch → Transistor T4 → Resistor R2 → Diode D3 → Alternator.

In both cases, the current flows to the base of transistor T4 to turn T4 on.

When transistor T4 is turned on, potential difference between the emitter and base of transistor T5 becomes zero, turning T5 off. The charge lamp then goes off.

A capacitor C1 is provided to stabilize voltage across resistor R3. Without this capacitor, transistor T4 repeats on and off at low voltage in the alternator, and the charge lamp lights dimly. This capacitor eliminates the ripples to prevent unstable operation.

■ During charging

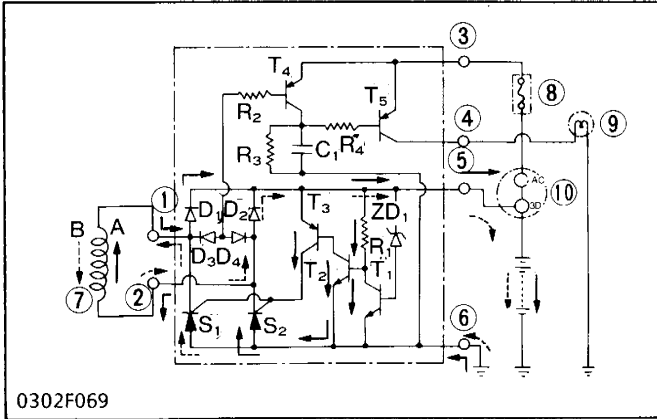

When the battery voltage is below the specified value (14.5 ± 0.5 V) of zener diode ZD1, a current does not flow to zener diode ZD1. Base current of transistor T1 does not flow, and transistor T1 is off. Current flows from resistor R1 to the base of transistor T2 to turn it on.

When transistor T2 is on, transistor T3 is forward biased and turns on, allowing a gate current of SCR's S1 and S2 to turn them on.

Therefore, when a generated voltage in alternator causes a current in \uparrow (A) direction, the charging current flows as follows:

Diode D1 \rightarrow Key Switch (Terminal No.30) \rightarrow Battery \rightarrow Ground \rightarrow SCR S2 \rightarrow Alternator.

With a current in \downarrow (B) direction, the charging current flows as follows:

Diode D2 \rightarrow Key Switch (Terminal No.30) \rightarrow Battery \rightarrow Ground \rightarrow SCR S1 \rightarrow Alternator.

■ Prevention of overcharging

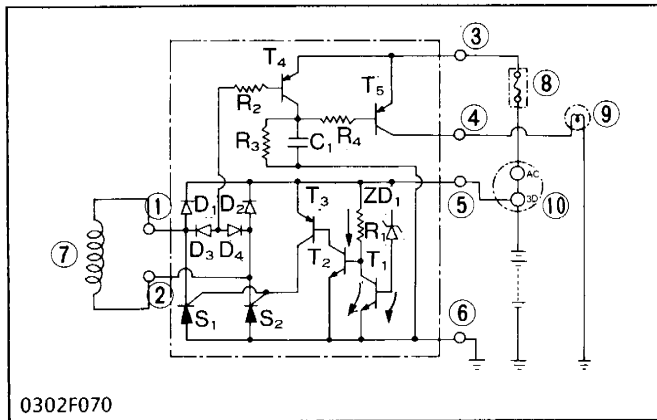

When the battery voltage rises over the specified value of zener diode ZD1, a current flows to the base of transistor T1 through ZD1, turning transistor T1 on. This causes a potential difference between the base and emitter of transistor T2 to become zero, turning off transistor T2 simultaneously.

Therefore, the current is no longer supplied to the gates of SCR's S1 and S2, turning off SCRs and the charging circuit is cut off.

S. DISASSEMBLING AND SERVICING



[1] ENGINE IDENTIFICATION

Model Name and Engine Serial Number

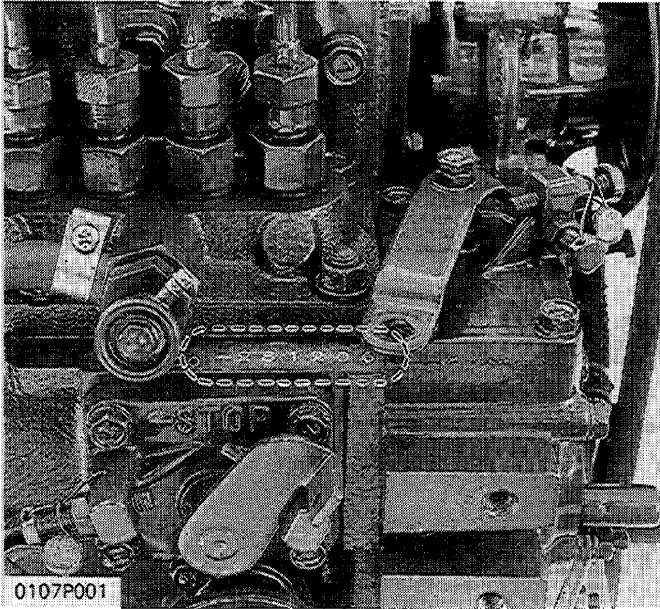

When contacting the manufacturer, always specify your engine model name and serial number.

Cylinder Number

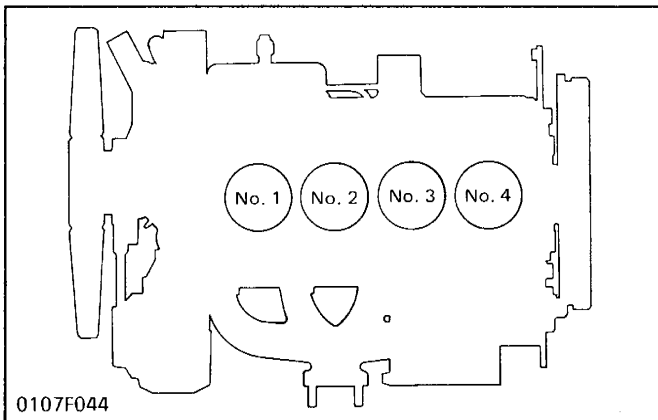

The cylinder numbers of 70 mm STROKE SERIES diesel engine are designated as shown in the figure.

The sequence of cylinder numbers is given as No. 1, No.2, No.3 and No.4 starting from the gear case side.

[2] GENERAL PRECAUTION

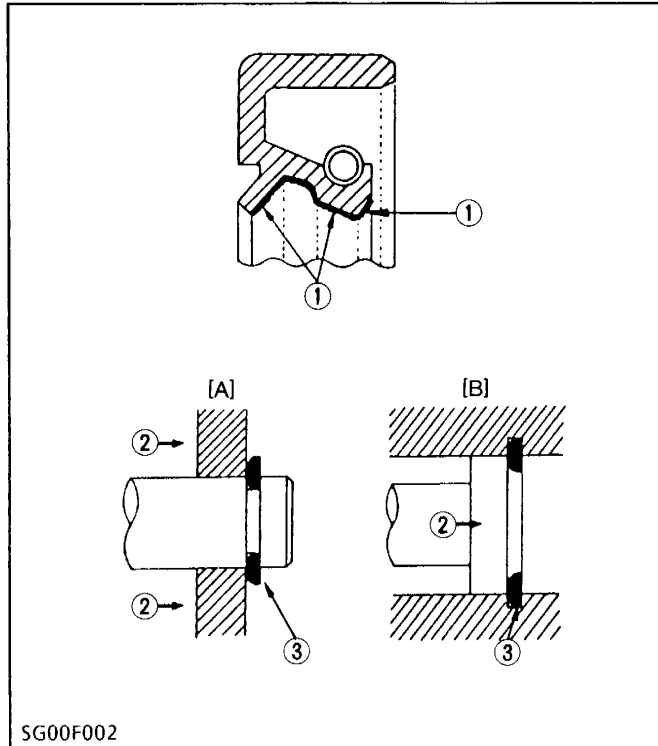

- During disassembly, carefully arrange removed parts in a clean area to prevent confusion later. Screws, bolts and nuts should be replaced in their original position to prevent reassembly errors.
- When special tools are required, use Kubota's genuine special tools. Special tools which are not frequently used should be made according to the drawings provided.
- Before disassembling or servicing live wires, make sure to always disconnect the grounding cable from the battery first.
- Remove oil and dirt from parts before measuring.
- Use only Kubota genuine parts for parts replacement to maintain engine performance and to ensure safety.
- Gaskets and O-rings must be replaced during reassembly. Apply grease to new O-rings or oil seals before assembling.
- When reassembling external or internal snap rings, position them so that the sharp edge faces against the direction from which force is applied.
- Be sure to perform run-in the serviced or reassembled engine. Do not attempt to give heavy load at once, or serious damage may result to the engine.

⚠ CAUTION

- All current Kubota production engines are asbestos-free. However, some engines, which were produced before the introduction of applying asbestos-free regulations, are still being used in the market. In servicing such as overhauling for the engine which contain asbestos, follow the specified safety rules and regulations and handle them with due care.

- (1) Grease
 (2) Force
 (3) Place the Sharp Edge against the Direction of Force

- [A] External Snap Ring
 [B] Internal Snap Ring

[3] TIGHTENING TORQUES

Screws, bolts and nuts must be tightened to the specified torque using a torque wrench, Several screws, bolts and nuts such as those used on the cylinder head must be tightened in proper sequence and at the proper torque.

(1) Tightening torques for special use screws, bolts and nuts



■ NOTE

- For "*" marked screws, bolts and nuts on the table, apply engine oil to their threads and seats before tightening.

Item	Size x Pitch	N·m	kgf·m	ft-lbs
* Head cover cap nuts	M7 x 1.0	6.9 to 8.8	0.7 to 0.9	5.1 to 6.5
* Head screws and nuts (Z500-B only)	M8 x 1.25	39.2 to 44.1	4.0 to 4.5	28.9 to 32.5
(Others)	M9 x 1.25	64.7 to 69.6	6.6 to 7.1	47.7 to 51.4
* Bearing case screws 1				
(Flange bolts)	M7 x 1.0	26.5 to 30.4	2.7 to 3.1	19.5 to 22.4
(Non-flange bolt)	M7 x 1.0	19.6 to 23.5	2.0 to 2.4	14.5 to 17.4
* Bearing case screws 2	M8 x 1.25	29.4 to 34.3	3.0 to 3.5	21.7 to 25.3
* Flywheel screws				
(Flange bolts)	M10 x 1.25	58.8 to 63.7	6.0 to 6.5	43.4 to 47.0
(Non-flange bolts)	M10 x 1.25	53.9 to 58.8	5.5 to 6.0	39.8 to 43.4
* Connecting rod screws	M7 x 0.75	26.5 to 30.4	2.7 to 3.1	19.5 to 22.4
* Rocker arm bracket nuts	M7 x 1.0	16.7 to 20.6	1.7 to 2.1	12.3 to 5.2
* Idle gear shaft screws	M6 x 1.0	9.8 to 11.3	1.00 to 1.15	7.2 to 8.3
Glow plugs	M10 x 1.25	19.6 to 24.5	2.0 to 2.5	14.5 to 18.1
Drain plug	M12 x 1.25	39.2 to 49.0	4.0 to 5.0	28.9 to 36.2
Nozzle holder assembly	M24 x 2.0	29.4 to 49.0	3.0 to 5.0	21.7 to 36.2
Oil switch taper screw	PT 1/8	14.7 to 19.6	1.5 to 2.0	10.8 to 14.5
Fuel limit lock nut	M12 x 1.0	27.5 to 34.3	2.8 to 3.5	20.3 to 25.3
Fuel limit cap nut	M12 x 1.0	24.5 to 29.4	2.5 to 3.0	18.1 to 21.7
Injection pipe retaining nuts	M12 x 1.5	14.7 to 24.5	1.5 to 2.5	10.8 to 8.1
Nozzle holder and nozzle retaining nut		58.8 to 78.5	6.0 to 8.0	43.4 to 57.9
Nozzle holder mounting screw	M24 x 2.0	39.2 to 49.0	4.0 to 5.0	28.9 to 36.2
* Crankshaft nut	M20 x 1.5	137.3 to 156.9	14.0 to 16.0	101.3 to 115.7

(2) Tightening torques for general use screws, bolts and nuts

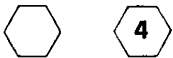
When the tightening torques are not specified, tighten the screws, bolts and nuts according to the table below.

Grade Nominal Diameter	Unit	Standard Screw and Bolt			Special Screw and Bolt		
		N·m	kgf·m	ft-lbs	N·m	kgf·m	ft-lbs
							
		SG00F004					
M 6		7.9 to 9.3	0.80 to 0.95	5.8 to 6.9	9.8 to 11.3	1.00 to 1.15	7.23 to 8.32
M 8		17.7 to 20.6	1.8 to 2.1	13.0 to 15.2	23.5 to 27.5	2.4 to 2.8	17.4 to 20.3
M10		39.2 to 45.1	4.0 to 4.6	28.9 to 33.3	48.1 to 55.9	4.9 to 5.7	35.4 to 41.2
M12		62.8 to 72.6	6.4 to 7.4	46.3 to 53.5	77.5 to 90.2	7.9 to 9.2	57.1 to 66.5

Screw and bolt material grades are shown by numbers punched on the screw and bolt heads. Prior to tightening, be sure to check out the numbers as shown below.

Punched Number	Screw and Bolt Material Grade
None or 4	Standard Screw and Bolt S41, S20C
7	Special Screw and Bolt S43C, S48C (Refined)

[4] TROUBLESHOOTING

Symptom	Probable Cause	Solution	Reference Page
Engine does not start	<ul style="list-style-type: none"> ● No fuel ● Air in the fuel system ● Water in the fuel system ● Fuel pipe clogged ● Fuel filter clogged ● Excessively high viscosity of fuel or engine oil at low temperature ● Fuel with low cetane number ● Fuel leak due to loose injection pipe retaining nut ● Incorrect injection timing ● Fuel cam shaft worn ● Injection nozzle clogged ● Injection pump malfunctioning ● Seizure of crankshaft, camshaft, piston, cylinder liner or bearing ● Compression leak from cylinder ● Improper valve timing ● Piston ring and liner worn ● Excessive valve clearance 	Replenish fuel Vent air Change fuel and repair or replace fuel system Clean Clean or change Use the specified fuel or engine oil Use the specified fuel Tighten nut Adjust Replace Clean Repair or replace Repair or replace Replace head gasket, tighten cylinder head bolt, glow plug and nozzle holder Correct or replace timing gear Replace Adjust	S-14 S-16 S-12, 15 S-52 S-23 S-42, 46 S-17
Starter does not run	<ul style="list-style-type: none"> ● Battery discharged ● Starter malfunctioning ● Key switch malfunctioning ● Wiring disconnected 	Charge Repair or replace Repair or replace Connect	
Engine revolution is not smooth	<ul style="list-style-type: none"> ● Fuel filter clogged or dirty ● Air cleaner clogged ● Fuel leak due to loose injection pipe retaining nut ● Injection pump malfunctioning ● Incorrect nozzle opening pressure ● Injection nozzle stuck or clogged ● Fuel over flow pipe clogged ● Governor malfunctioning 	Clean or change Clean or change Tighten nut Repair or replace Adjust Repair or replace Clean Repair	S-16 S-16 S-53
Either white or blue exhaust gas is observed	<ul style="list-style-type: none"> ● Excessive engine oil ● Piston ring and liner worn or stuck ● Incorrect injection timing ● Deficient compression 	Reduce to the specified level Repair or replace Adjust Adjust top clearance	S-42, 46 S-52 S-23
Either black or dark gray exhaust gas is observed	<ul style="list-style-type: none"> ● Overload ● Low grade fuel used ● Fuel filter clogged ● Air cleaner clogged 	Lessen the load Use the specified fuel Clean or change Clean or change	
Deficient output	<ul style="list-style-type: none"> ● Incorrect injection timing ● Engine's moving parts seem to be seizing ● Uneven fuel injection ● Deficient nozzle injection ● Compression leak 	Adjust Repair or replace Repair or replace the injection pump Repair or replace the nozzle Replace head gasket, tighten cylinder head bolt, glow plug and nozzle holder	S-52 S-53

Symptom	Probable Cause	Solution	Reference Page
Excessive lubricant oil consumption	<ul style="list-style-type: none"> ● Piston ring's gap facing the same direction ● Oil ring worn or stuck ● Piston ring groove worn ● Valve stem and guide worn ● Crankshaft bearing, and crank pin bearing worn 	Shift ring gap direction Replace Replace the piston Replace Replace	S-32 S-42 S-43
Fuel mixed into lubricant oil	<ul style="list-style-type: none"> ● Injection pump's plunger worn ● Injection pump broken 	Replace pump element or pump Replace	S-52
Water mixed into lubricant oil	<ul style="list-style-type: none"> ● Head gasket defective ● Cylinder block or cylinder head flawed 	Replace Replace	
Low oil pressure	<ul style="list-style-type: none"> ● Engine oil insufficient ● Oil strainer clogged ● Relief valve stuck with dirt ● Relief valve spring weaken or broken ● Excessive oil clearance of crankshaft bearing ● Excessive oil clearance of crank pin bearing ● Excessive oil clearance of rocker arm bearing ● Oil passage clogged ● Different type of oil ● Oil pump defective 	Replenish Clean Clean Replace Replace Replace Clean Use the specified type of oil Repair or replace	S-31 S-12,15
High oil pressure	<ul style="list-style-type: none"> ● Different type of oil ● Relief valve defective 	Use the specified type of oil Replace	S-12,15
Engine overheated	<ul style="list-style-type: none"> ● Engine oil insufficient ● Fan belt broken or elongated ● Cooling water insufficient ● Radiator net and radiator fin clogged with dust ● Inside of radiator corroded ● Cooling water flow route corroded ● Radiator cap defective ● Overload running ● Head gasket defective ● Incorrect injection timing ● Unsuitable fuel used 	Replenish Change or adjust Replenish Clean Clean or replace Clean or replace Replace Loosen the load Replace Adjust Use the specified fuel	S-15
Battery quickly discharge	<ul style="list-style-type: none"> ● Battery electrolyte insufficient ● Fan belt slips ● Wiring disconnected ● Rectifier defective ● Alternator defective ● Battery defective 	Replenish distilled water and charge Adjust belt tension or change Connect Replace Replace Change	

[5] SERVICING SPECIFICATIONS**(1) ENGINE BODY****Cylinder Head**

Item		Factory Specification	Allowable Limit
Cylinder head surface flatness		–	0.05 mm 0.0019 in.
Top clearance		0.6 to 0.8 mm 0.0237 to 0.0315 in.	–
Cylinder head gasket shim thickness		0.2 mm 0.0079 in.	–
Cylinder head gasket thickness (Grommet section)	Free	1.15 to 1.30 mm 0.0453 to 0.0512 in.	–
	Tightened	1.05 to 1.15 mm 0.0413 to 0.0453 in.	–
Compression pressure		3.09 MPa 31.5 kgf/cm ² , 448 psi	2.32 MPa 23.7 kgf/cm ² , 337 psi
Variance among cylinders			10% or less

Valves

Valve clearance (Cold)			0.145 to 0.185 mm 0.0057 to 0.0072 in.	–
Valve seat width	IN.		2.12 mm 0.0835 in.	–
		VH1100-B only	1.74 mm 0.0685 in.	–
	EX.		2.12 mm 0.0835 in.	–
Valve seat angle	IN.		0.785 rad. 45°	–
		VH1100-B only	1.047 rad. 60°	–
	EX.		0.785 rad. 45°	–
Valve face angle	IN.		0.794 rad. 45.5°	–
		VH1100-B only	1.051 rad. 60°15'	–
	EX.		0.794 rad. 45.5°	–
Valve recessing			0.9 to 1.1 mm 0.036 to 0.043 in.	1.3 mm 0.051 in.
Clearance between valve stem and valve guide			0.035 to 0.065 mm 0.0014 to 0.0025 in.	0.1 mm 0.0039 in.
Valve stem O.D.			6.960 to 6.975 mm 0.2741 to 0.2746 in.	–
Valve guide I.D.			7.010 to 7.025 mm 0.2760 to 0.2765 in.	–

Valve Timing

Item		Factory Specification	Allowable Limit
Intake valve	Open	0.35 rad. (20°) before T.D.C.	-
	Close	0.79 rad. (45°) after B.D.C.	-
Exhaust valve	Open	0.87 rad. (50°) before B.D.C.	-
	Close	0.26 rad. (15°) after T.D.C.	-

Valve Spring

Free length	35.1 to 35.6 mm 1.382 to 1.401 in.	34.8 mm 1.370 in.
Setting load / setting length	73.5 N/31.0 mm 7.5 kgf/31.0 mm, 16.5 lbs/1.22 in.	62.8 N/31.0 mm 6.4 kgf/31.0 mm, 14.1 lbs/1.22 in.
Tilt	-	1.3 mm 0.051 in.

Rocker Arm

Clearance between rocker arm shaft and bearing	0.016 to 0.068 mm 0.0006 to 0.0027 in.	0.12 mm 0.0047 in.
Rocker arm shaft O.D.	10.973 to 10.984 mm 0.4320 to 0.4324 in.	-
Rocker arm bearing I.D.	11.000 to 11.041 mm 0.4331 to 0.4347 in.	-

Tappet

Clearance between tappet and guide	0.020 to 0.062 mm 0.0008 to 0.0024 in.	0.1 mm 0.0039 in.
Tappet O.D.	19.959 to 19.980 mm 0.7858 to 0.7866 in.	-
Tappet guide I.D.	20.000 to 20.021 mm 0.7874 to 0.7882 in.	-

Camshaft

Camshaft side clearance	0.07 to 0.22 mm 0.0028 to 0.0087 in.	0.3 mm 0.0118 in.
Camshaft alignment	-	0.01 mm 0.0004 in.
Cam height (IN., EX.)	26.88 mm 1.0583 in.	26.83 mm 1.0563 in.
Oil clearance of camshaft	0.050 to 0.091 mm 0.0020 to 0.0036 in.	0.15 mm 0.0059 in.
Camshaft journal O.D.	32.934 to 32.950 mm 1.2966 to 1.2972 in.	
Camshaft bearing I.D.	33.000 to 33.025 mm 1.2992 to 1.3002 in.	

Timing Gear

Item	Factory Specification	Allowable Limit
Timing gear backlash	0.042 to 0.115 mm 0.0017 to 0.0045 in.	0.2 mm 0.0079 in.
Idle gear side clearance	0.20 to 0.51 mm 0.0079 to 0.0201 in.	0.8 mm 0.0315 in.
Clearance between idle gear shaft and idle gear bushing Idle gear shaft O.D. Idle gear bushing I.D.	0.016 to 0.045 mm 0.0006 to 0.0018 in. 17.973 to 17.984 mm 0.7076 to 0.7080 mm 18.000 to 18.018 mm 0.7087 to 0.7094 in.	0.1 mm 0.0039 in. - -
Engine serial number: 407507 and beyond (Z500-B, Z600-B, ZH600-B, D650-B, D750-B, D850-B, DH850-B, V1100-B, VH1100-B, V1200-B) 393782 and beyond (D950-B)		
Clearance between idle gear shaft and idle gear bushing Idle gear shaft O.D. Idle gear bushing I.D.	0.020 to 0.054 mm 0.0008 to 0.0021 in. 23.967 to 23.980 mm 0.9436 to 0.9441 in. 24.000 to 24.021 mm 0.9449 to 0.9457 in.	0.1 mm 0.0039 in. - -
Engine serial number: 599860 and beyond (Z500-B, Z600-B, ZH600-B, D650-B, D750-B, D850-B, DH850-B, D950-B, V1100-B, VH1100-B, V1200-B)		
Clearance between idle gear shaft and idle gear bushing Idle gear shaft O.D. Idle gear bushing I.D.	0.020 to 0.054 mm 0.0008 to 0.0021 in. 29.967 to 29.980 mm 1.1798 to 1.1803 in. 30.000 to 30.021 mm 1.1811 to 1.1819 in.	0.1 mm 0.0039 in. - -

Piston-Piston Ring

Piston Pin Bore	20.000 to 20.013 mm 0.7874 to 0.7879 in.	20.03 mm 0.7886 in.
Clearance between compression ring 2 and ring groove Piston ring groove width Compression ring 2 width	0.085 to 0.112 mm 0.0033 to 0.0044 in. 1.555 to 1.570 mm 0.0613 to 0.0618 in. 1.458 to 1.470 mm 0.0574 to 0.0579 in.	0.20 mm 0.0079 in. - -
Clearance between oil ring and ring groove Piston ring groove width Oil ring width	0.020 to 0.055 mm 0.0008 to 0.0021 in. 4.010 to 4.030 mm 0.1579 to 0.1587 in. 3.975 to 3.990 mm 0.1565 to 0.1571 in.	0.20 mm 0.0079 in. - -

Piston-Piston Ring (Continued)

Item		Factory Specification	Allowable I
Ring gap	Compression ring 1	0.25 to 0.40 mm 0.0098 to 0.0157 in.	1.25 mm 0.0492 in
		D950-B,V1200-B only 0.20 to 0.35 mm 0.0079 to 0.0138 in.	
	Compression ring 2	0.25 to 0.40 mm 0.0098 to 0.0157 in.	1.25 mm 0.0492 in
		D950-B only 0.30 to 0.45 mm 0.0118 to 0.0177 in.	
	Oil ring	0.25 to 0.40 mm 0.0098 to 0.0157 in.	1.25 mm 0.0492 in
		D650-B, D750-B only 0.20 to 0.40 mm 0.0079 to 0.0157 in.	

Connecting Rod

Connecting rod alignment	—	0.05 mm 0.0020 in
Clearance between piston pin and small end bushing	0.014 to 0.038 mm 0.0006 to 0.0015 in.	0.15 mm 0.0059 in
Piston pin O.D.	20.002 to 20.011 mm 0.7875 to 0.7878 in.	—
Small end bushing I.D.	20.025 to 20.040 mm 0.7884 to 0.7890 in.	—

Crankshaft

Crankshaft alignment	—	0.02 mm 0.0008 in
Oil clearance between crankshaft and crankshaft bearing 1	0.034 to 0.106 mm 0.0013 to 0.0042 in.	0.2 mm 0.0079 in
Crankshaft O.D.	43.934 to 43.950 mm 1.7297 to 1.7303 in.	—
Crankshaft bearing 1 I.D.	43.984 to 44.040 mm 1.7317 to 1.7339 in.	—
Oil clearance between crankshaft and crankshaft bearing 2	0.034 to 0.092 mm 0.0013 to 0.0036 in.	0.2 mm 0.0079 in
Crankshaft O.D.	43.934 to 43.950 mm 1.7297 to 1.7303 in.	—
Crankshaft bearing 2 I.D.	43.984 to 44.026 mm 1.7317 to 1.7333 in.	—
Oil clearance between crank pin and crank pin bearing	0.029 to 0.087 mm 0.0011 to 0.0034 in.	0.2 mm 0.0079 in
Crank pin O.D.	36.959 to 36.975 mm 1.4551 to 1.4557 in.	—
Crank pin bearing I.D.	37.004 to 37.046 mm 1.4569 to 1.4585 in.	—
Crankshaft side clearance	0.15 to 0.31 mm 0.0059 to 0.0122 in.	0.5 mm 0.0197 in
Crankshaft sleeve wear	—	0.1 mm 0.0039 in

Cylinder Liner

Item		Factory Specification	Allowable Limit
Cylinder liner I.D.	D650-B	64.000 to 64.019 mm 2.5197 to 2.5204 in.	+ 0.15 mm 0.0059 in.
	Z500-B, D750-B	68.000 to 68.019 mm 2.6772 to 2.6779 in.	
	D600-B, ZH600-B D850-B, DH850-B V1100-B VH1100-B	72.000 to 72.019 mm 2.8347 to 2.8354 in.	
	D950-B, V1200-B	75.000 to 75.019 mm 2.9528 to 2.9535 in.	
Oversized cylinder liner I.D.		+ 0.5 mm 0.0197 in.	

(2) LUBRICATING SYSTEM**Oil Pump**

Engine oil pressure	At idle speed		68 kPa 0.7 kgf/cm ² , 10 psi	–
	At rated speed		196 to 441 kPa 2.0 to 4.5 kgf/cm ² , 29 to 64 psi	196 kPa 2.0 kgf/cm ² , 29 psi
		V1100-B V1200-B only	167 to 343 kPa 1.7 to 3.5 kgf/cm ² , 24 to 49 psi	167 kPa 1.7 kgf/cm ² , 24 psi
Clearance between inner rotor and outer rotor			0.11 to 0.15 mm 0.0043 to 0.0059 in.	0.2 mm 0.0079 in.
Clearance between outer rotor and pump body			0.07 to 0.15 mm 0.0028 to 0.0059 in.	0.25 mm 0.0098 in.
End clearance between inner rotor and cover			0.08 to 0.13 mm 0.0031 to 0.0051 in.	0.2 mm 0.0079 in.

(3) COOLING SYSTEM**Thermostat**

Thermostat's valve opening temperature	69.5 to 72.5°C 157.1 to 162.5°F	–
Temperature at which thermostat completely opens	85°C 185°F	–

(4) FUEL SYSTEM**Injection Pump**

Item	Factory Specification	Allowable Limit
Injection timing	0.402 to 0.436 rad. before T.D.C. (23° to 25°)	—
Fuel tightness of pump element	—	14.7 MPa 150 kgf/cm ² , 2133 psi
Fuel tightness of delivery valve	More 10 seconds 14.7 → 13.7 MPa 150 → 140 kgf/cm ² 2133 → 1990 psi	5 seconds 14.7 → 13.7 MPa 150 → 140 kgf/cm ² 2133 → 1990 psi

Injection Nozzle

Fuel injection pressure	13.73 to 14.71 MPa 140 to 150 kgf/cm ² 1991 to 2133 psi	—
Fuel tightness of nozzle valve seat	When the pressure is 12.75 MPa (130 kgf/cm ² , 1849 psi), the valve seat must be fuel tightness.	—

(5) ELECTRICAL SYSTEM**Starter**

Commutator O.D.	(1 kW)	30.0 mm 1.1811 in.	29.0 mm 1.1417 in.
	(0.8 kW)	28.0 mm 1.1024 in.	27.0 mm 1.0630 in.
Mica undercut		0.5 to 0.8 mm 0.0197 to 0.0315 in.	0.2 mm 0.079 in.
Brush length	(1 kW)	13.0 mm 0.5118 in.	8.5 mm 0.3346 in.
	(0.8 kW)	16.0 mm 0.6299 in.	10.5 mm 0.4134 in.

Alternator

No-load voltage	AC 20 V at 5200 rpm	—
-----------------	---------------------	---

Glow Plug

Glow plug resistance	1.0 to 1.2 Ω	—
----------------------	--------------	---

[6] MAINTENANCE CHECK LIST

To maintain long-lasting and safe engine performance, make it a rule to carry out regular inspections by following the table below.

Item	Service Interval									
	Every 50 hrs	Every 100 hrs	Every 150 hrs	Every 200 hrs	Every 400 hrs	Every 800 hrs	Every 1000 hrs	Every three months	Every one year	Every two years
Checking fuel pipes and clamps	○									
Changing engine oil *		○								
Cleaning air filter element		○								
Cleaning fuel filter		○								
Checking fan belt tension and damage		○								
Checking water pipes and clamps			○							
Changing oil filter cartridge *				○						
Changing fuel filter element					○					
Cleaning radiator interior					○					
Changing radiator cleaner and coolant								○		
Changing air filter element									○	
Checking valve clearance						○				
Checking nozzle injection pressure							○			
Changing water pipes and clamps										○
Changing fuel pipes and clamps										○

* Change engine oil and oil filter cartridge after the first 50 hours of operation.

CAUTION

- When changing or inspecting, be sure to level and stop the engine.

■ Lubricating Oil

With the emission control now in effect, the CF-4 and CG-4 lubricating oils have been developed for use of a low-sulfur fuel on-road vehicle engines. When an off-road vehicle engine runs on a high-sulfur fuel, it is advisable to employ the CF, CD or CE lubricating oil with a high total base number. If the CF-4 or CG-4 lubricating oil is used with a high-sulfur fuel, change the lubricating oil at shorter intervals.

- **Lubricating oil recommended when a low-sulfur or high-sulfur fuel is employed.**

Lubricating oil class	Fuel		Remarks
	Low sulfur	High sulfur	
CF	recommended	recommended	TBN ≥ 10
CF-4	recommended	not recommended	
CG-4	recommended	not recommended	

[7] CHECK AND MAINTENANCE

(1) Daily Check Points

Checking Engine Oil Level

1. Level the engine.
2. To check the oil level, draw out the dipstick, wipe it clean, reinsert it, and draw it out again.
Check to see that the oil level lies between the two notches.
3. If the level is too low, add new oil to the specified level.

■ IMPORTANT

- When using an oil of different maker or viscosity from the previous one, drain old oil. Never mix two different types of oil.

Checking and Replenish Coolant

1. Remove the radiator cap and check to see that the coolant level is just bellow the port.
2. If low, add clean water and antifreeze.



CAUTION

- Do not remove the radiator cap until coolant temperature is below its boiling point.
Then loosen the cap slightly to relieve any excess pressure before removing the cap completely.

■ IMPORTANT

- Be sure to close the radiator cap securely. If the cap is loose or improperly closed, water may leak out and the engine could overheat.
- Do not use an antifreeze and scale inhibitor at the same time.

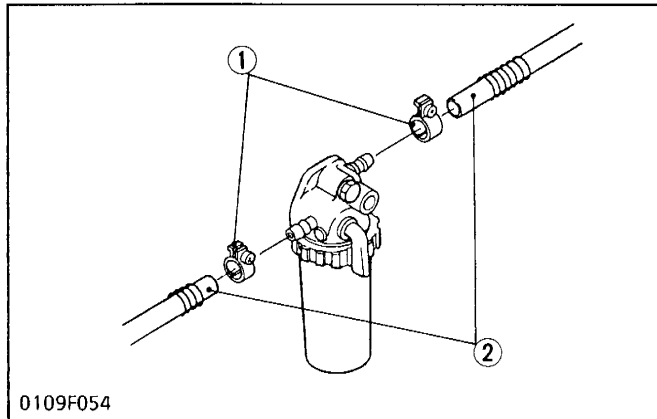
(2) Check Point of Every 50 hours**Checking Fuel Pipe**

1. If the clamp (1) is loose, apply oil to the threads and securely retighten it.
2. The fuel pipe (2) is made of rubber and ages regardless of the period of service.
Change the fuel pipe together with the clamp every two years.
3. However, if the fuel pipe and clamp are found to be damaged or deteriorate earlier than two years, then change or remedy.
4. After the fuel pipe and the clamp have been changed, bleed the fuel system.

⚠ CAUTION

- Stop the engine when attempting the check and change prescribed above.

- (1) Clamp
(2) Fuel Pipe

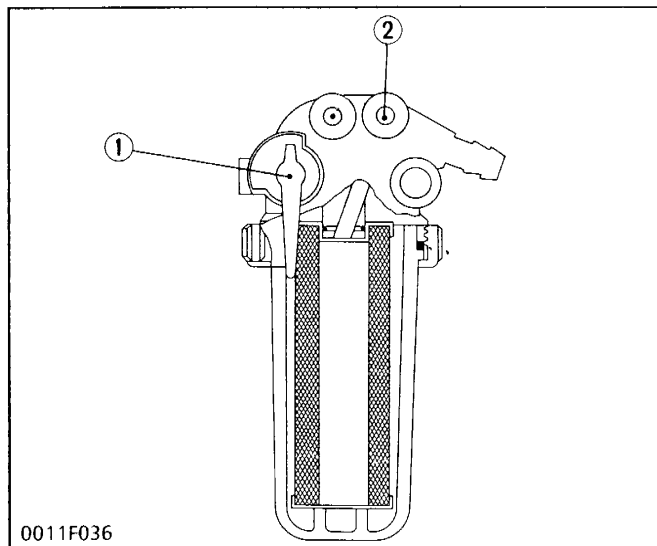
**(When bleeding fuel system)**

1. Fill the fuel tank with fuel, and open the fuel cock (1).
2. Loosen the air vent plug (2) of the fuel filter a few turns.
3. Screw back the plug when bubbles do not come up any more.
4. Open the air vent cock on top of the fuel injection pump.
5. Retighten the plug when bubbles do not come up any more.

■ NOTE

- Always keep the air vent plug on the fuel injection pump closed except when air is vented, or it may cause the engine to stop.

- (1) Fuel Cock
(2) Air Vent Plug

(3) Check Point of Every 100 hours**Changing Engine Oil**

1. After warming up, stop the engine.
2. To change the used oil, remove the drain plug at the bottom of the engine and drain off the oil completely.
3. Reinstall the drain plug.
4. Fill the new oil up to the upper notch on the dipstick.

■ IMPORTANT

- Engine oil should be MIL-L-46152/MIL-L-2104C or have properties of API classification CD/CE/CF grades.
- Change the type of engine oil according to the ambient temperature.
 - Above 25°C (77°F)----- SAE 30 or 10W-30
 - 0°C to 25°C (32°F to 77°F)----- SAE 20 or 10W-30
 - Below 0°C (32°F)----- SAE 10 W or 10W-30

Changing Engine Oil Filter Cartridge

1. Remove the oil filter cartridge with a filter wrench.
2. Apply engine oil to the rubber gasket on the new cartridge.
3. Screw the new cartridge in by hand.

■ NOTE

- Over-tightening may cause deformation of rubber gasket.
- After cartridge has been replaced, engine oil normally decreases a little. Check the oil level and add new oil to the specified level.

Checking Fan Belt Tension and Checking Fan Belt**Damage**

1. Check the fan belt for damage.
2. Check if the fan belt is worn and sunk in the pulley groove.
3. Replace the fan belt if the belt is damaged or nearly worn out and deeply sunk in the pulley groove.
4. Press the fan belt between fan pulley and pulley at force of 98N (10 kgf, 22 lbs). Check if the fan belt deflection is 10 to 12 mm (0.394 to 0.472 in.)
5. If the deflection is not within the factory specifications, adjust with the tension pulley adjusting bolts (1).

(1) Tension Pulley Adjusting Bolts

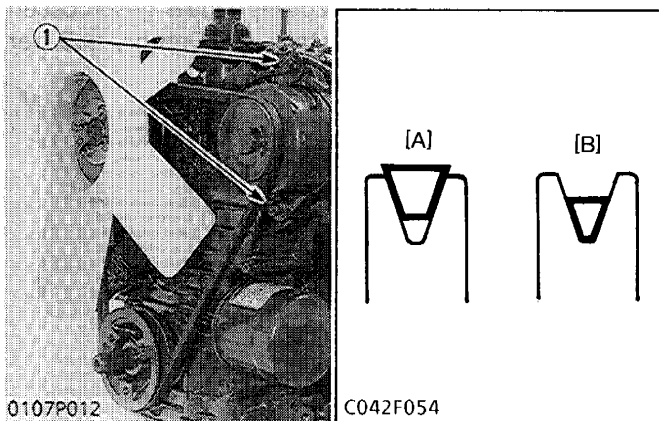
[A] Good**[B] Bad**

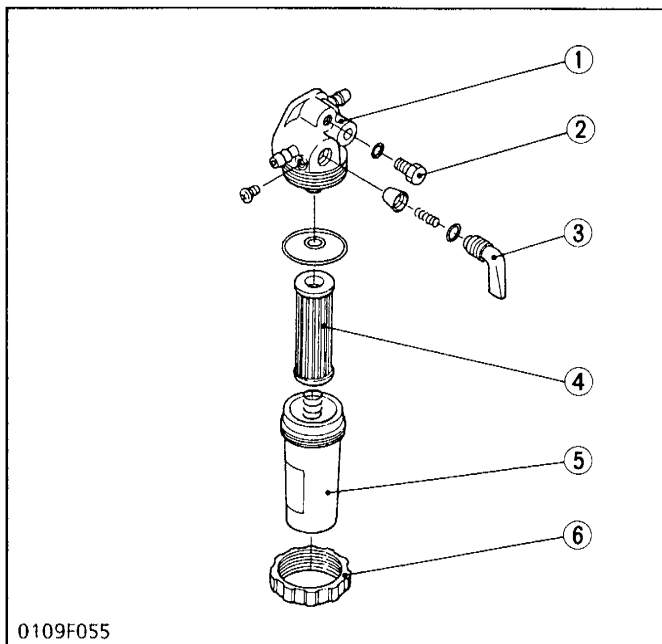

Cleaning Fuel Filter

1. Close the fuel filter cock (3).
2. Unscrew the screw ring (6) and remove the cup (5), and rinse the inside with kerosene.
3. Take out the element (4) and dip it in the kerosene to rinse.
4. After cleaning, reassemble the fuel filter, keeping out dust and dirt.
5. Bleed the fuel system.

■ IMPORTANT

- If dust and dirt enter the fuel, the fuel injection pump and injection nozzle will wear quickly. To prevent this, be sure to clean the fuel filter cup periodically.

- (1) Cock Body
- (2) Air Vent Plug
- (3) Filter Cock
- (4) Filter Element
- (5) Filter Cup
- (6) Screw Ring

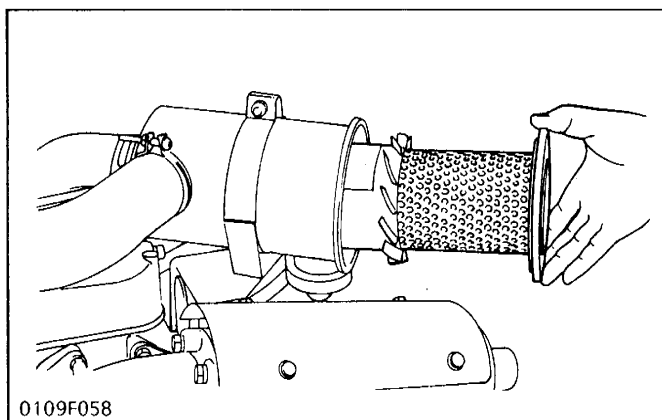

Cleaning Air Cleaner

1. The air cleaner uses a dry element. Never apply oil to it.
2. Remove and clean out the dust cup before it becomes half full with dust.
3. When the air filter element is dusty, clean it.

■ NOTE

- Change the element once a year or every 6th cleaning.

■ IMPORTANT

- Install the air cleaner dust cup with "TOP" indicated on the rear of the cup in the upside. If the dust cup is mounted incorrectly, dust or dirt does not collect in the cup, and direct attachment of the dust to the element will cause its life time to shorten to a great extent.



Cleaning Air Filter Element

- **When dry dust adheres**
Use clean dry compressed air on the inside of the element.
Pressure of compressed air must be under 205 kPa (2.1kgf/cm², 30 psi).
Maintain reasonable distance between the nozzle and the filter.

(4) Check Point of Every 800 hours

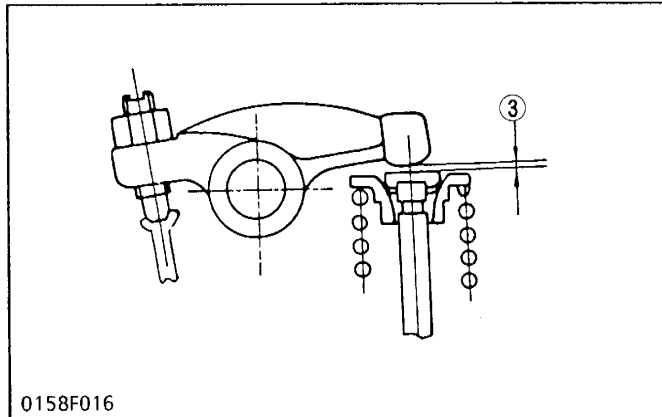
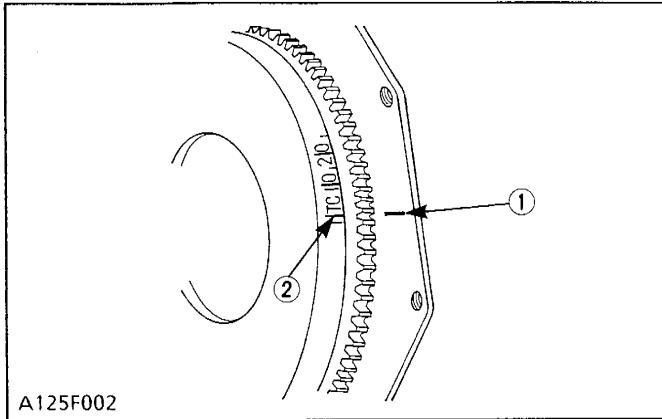

- (1) Notched Mark
- (2) TC Mark Line
- (3) Valve Clearance

Checking Valve Clearance

IMPORTANT

- Valve clearance must be checked and adjusted when engine is cold.

1. Remove the head cover.
2. Align the "1TC" mark on the flywheel and notched mark (2) on the plate so that the No. 1 piston comes to the compression or overlap top dead center.
3. Check the following valve clearance marked with "o" using a feeler gauge.
4. If the clearance is not within the factory specifications, adjust with the adjusting screw.

Valve clearance	Factory spec.	0.145 to 0.185 mm 0.0059 to 0.0073 in.
-----------------	---------------	---

NOTE

- The "TC" marking on the flywheel is just for No. 1 cylinder. There is no "TC" marking for the other cylinders.
- No. 1 piston comes to the T.D.C. position when the "TC" marking is aligned with the punch mark of the rear end plate. Turn the flywheel 0.26 rad. (15°) clockwise and counter-clockwise to see if the piston is at the compression top dead center or the overlap position. Now referring to the table below, readjust the valve clearance. (The piston is at the top dead center when both the In. and EX valves do not move; it is at the overlap position when both the valves move).
- Finally turn the flywheel 6.28 rad.(360°) to make sure the "TC" marking and the punch mark are perfectly aligned. Adjust all the other valve clearances as required.
- After turning the flywheel counterclockwise twice or three times, recheck the valve clearance.
- After adjusting the valve clearance, firmly tighten the lock nut of the adjusting screw.

Engine Model Valve arrangement Adjustable cylinder Location of piston	Z500-B Z600-B ZH600-B		D650-B,D750-B D850-B,DH850-B D950-B		V1100-B VH1100-B V1200-B	
	IN.	EX.	IN.	EX.	IN.	EX.
When No. 1 piston is compression top dead center	1st	o	o	o	o	o
	2nd		o		o	
	3rd			o		o
	4th					
When No. 1 piston is overlap position	1st					
	2nd	o		o		o
	3rd				o	o
	4th					o

(5) Check Points of 1000 hours

CAUTION

- Check the nozzle injection pressure and condition after confirming that there is nobody standing in the direction the fume goes. If the fume from the nozzle directly contacts the human body, cells may be destroyed and blood poisoning may be caused.

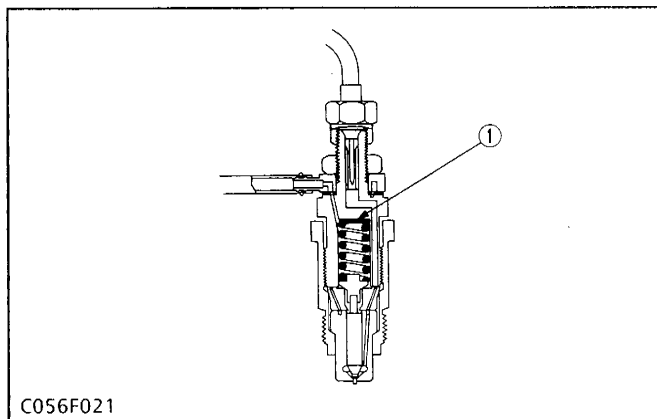
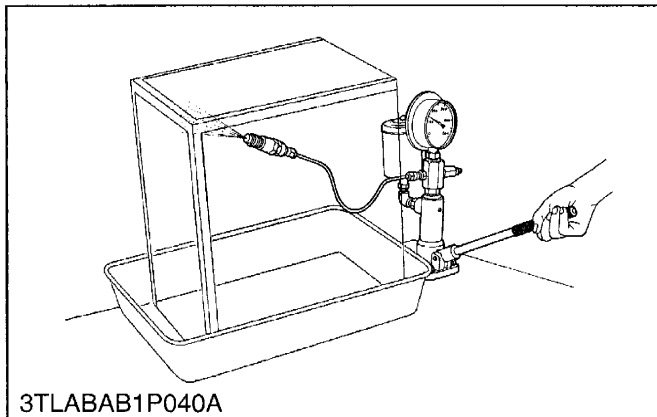

Checking Nozzle Injection Pressure

1. Set the injection nozzle to the nozzle tester (Code No: 07909-31361).
2. Slowly move the tester handle to measure the pressure at which fuel begins jetting out from the nozzle.
3. If the measurement is not within the factory specifications, disassemble the injection nozzle, and change adjusting washer (1) until the proper injection pressure is obtained. (See page S-117)
4. If the spraying condition is defective, replace the nozzle piece.

(Reference)

- Pressure variation with 0.1 mm (0.0039 in.) difference of adjusting washer thickness.
Approx. 981 kPa (10 kgf/cm², 142 psi)

(1) Adjusting Washer

[8] SPECIAL TOOLS

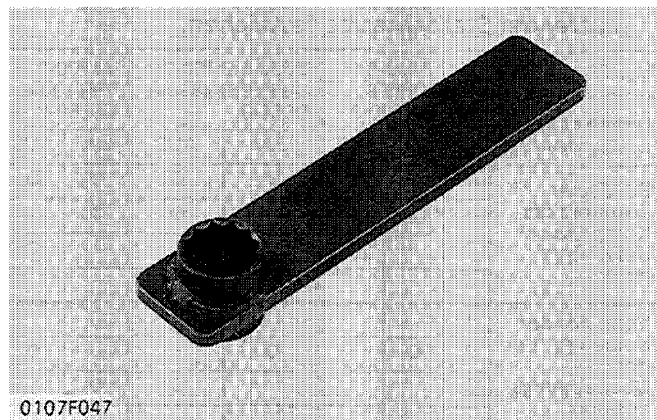

Socket Wrench 29

Code No: 07916-31841

Application: Use to take off and to fix the crankshaft nut of diesel engine.

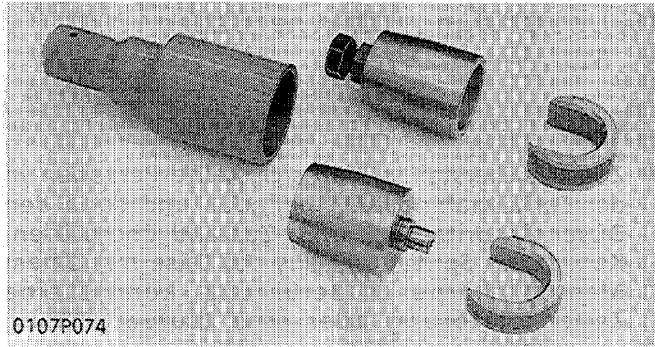

Auxiliary Socket For Fixing Crankshaft Sleeve

Code No: 07916-33011

Application: Use to fix the crankshaft sleeve of the diesel engine.

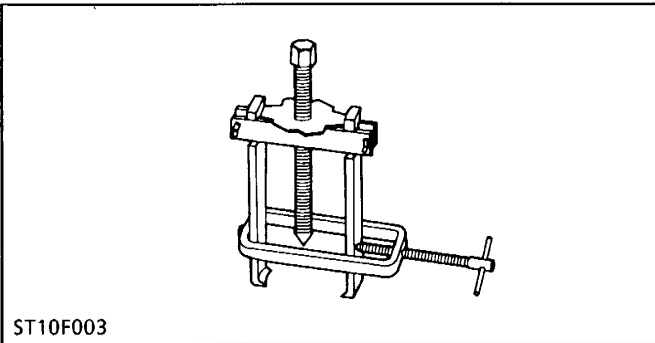

Special-use Puller Set

Code No: 07916-09032

Application: Use for pulling out bearings, gears and other parts.

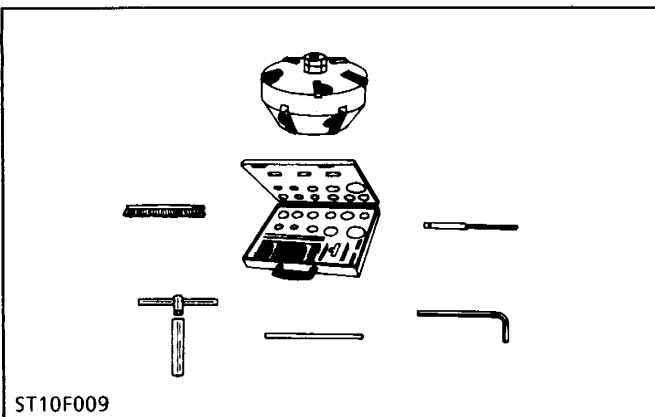

Valve Seat Cutter Set

Code No: 07909-33102

Application: Use for correcting valve seats.

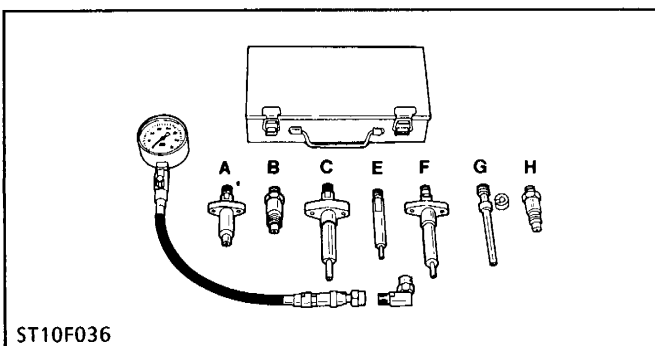

Diesel Engine Compression Tester

Code No: 07909-30208

Application: Use for measuring diesel engine compression pressure.

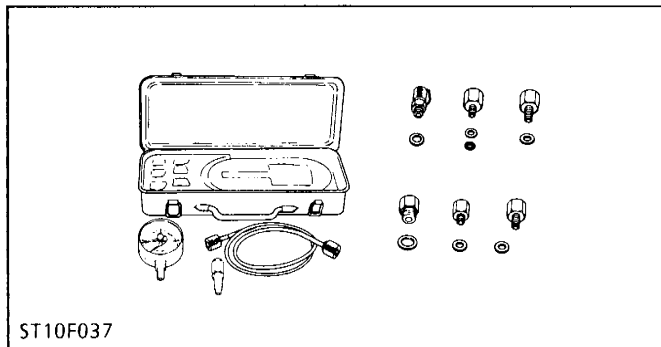

Oil Pressure Tester

Code No: 07916-32031

Application: Use for measuring lubricating oil pressure.

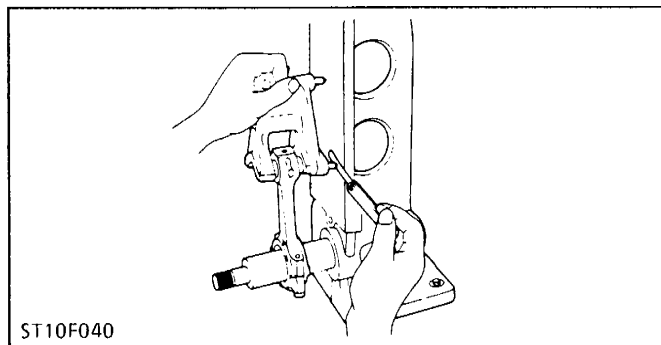

Connecting Rod Alignment Tool

Code No: 07909-31661

Application: Use for checking the connecting rod alignment.

Applicable: Connecting rod big end I.D. 30 to 75 mm (1.18 to 2.95 in. dia.) Connecting rod length 65 to 330 mm (2.56 to 12.99 in.)

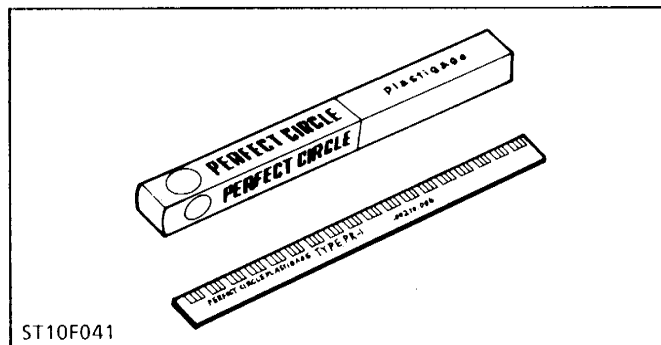

Press Gauge

Code No: 07909-30241

Application: Use for checking the oil clearance between crankshaft and bearing, etc.

Measuring range:
 Green — 0.025 to 0.076 mm (0.001 to 0.003 in.)
 Red — 0.051 to 0.152 mm (0.002 to 0.006 in.)
 Blue — 0.102 to 0.229 mm (0.004 to 0.009 in.)

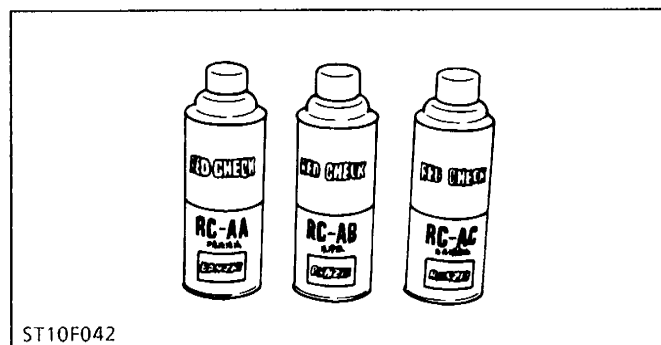

Red Check (Crack check liquid)

Code No: 07909-31371

Application: Use for checking cracks on cylinder head, cylinder block, etc.

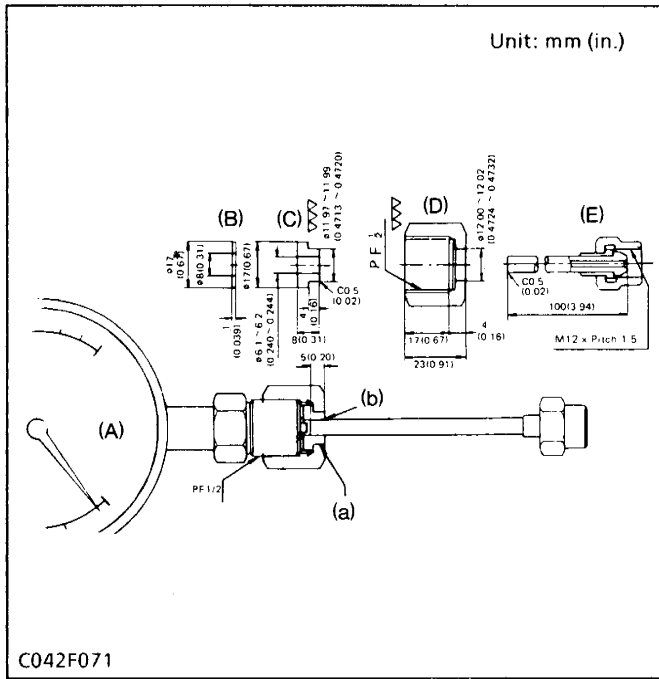

NOTE

- The following special tools are not provided, so make them referring to the figures.

Injection Pump Pressure Tester

Application: Use for checking fuel tightness of the injection pump.

A	Pressure gauge Full scale: More than 29.4 MPa (300 kg/cm ² , 4267 psi)
B	Copper gasket
C	Flange (Material: Steel)
D	Hex. nut 27 mm (1.06 in.) across the flat (Material: Steel)
E	Injection Pipe

- (a) Adhesive application
- (b) Fillet welding on the enter circumference

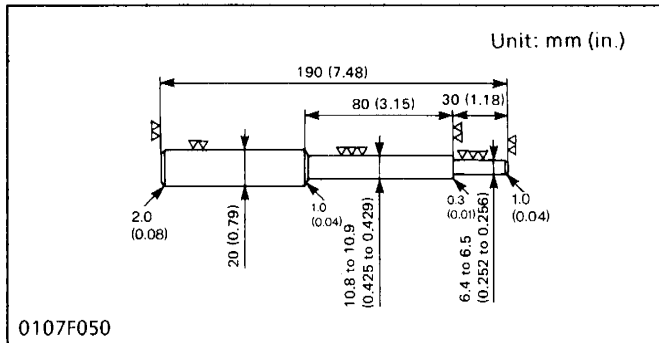

Valve Guide Replacing Tool

Application: Use to press out and to press fit the valve guide.

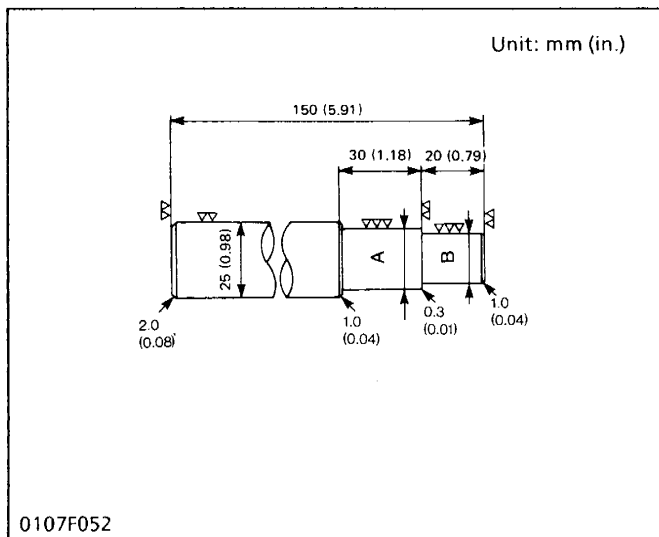

Idle gear Bushing Replacing Tool

Application: Use to press out and to press fit the idle gear bushing.

Bushing I.D.	A	B
18 mm 0.7087 in.	19.90 to 19.95 mm 0.7835 to 0.7854 in.	17.90 to 17.95 mm 0.7047 to 0.7067 in.
24 mm 0.9449 in.	25.90 to 25.95 mm 1.0197 to 1.0217 in.	23.90 to 23.95 mm 0.9409 to 0.9429 in.
30 mm 1.1811 in.	31.90 to 31.95 mm 1.2559 to 1.2579 in.	29.90 to 29.95 mm 1.1772 to 1.1791 in.

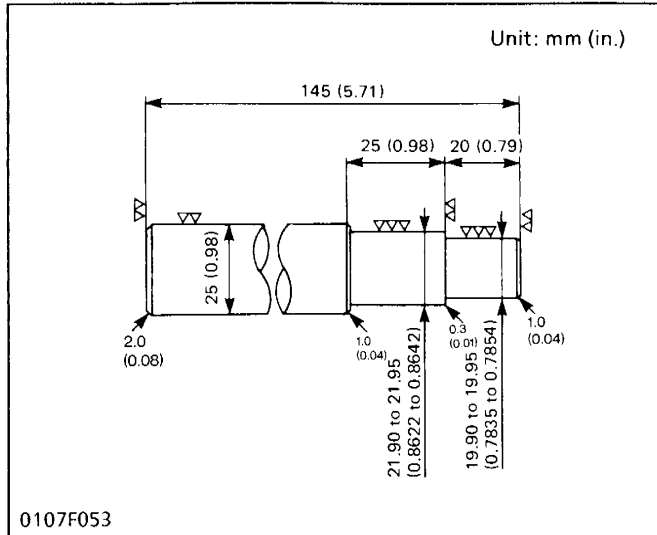

Small End Bushing Replacing Tool

Application: Use to press out and to press fit the small end bushing.

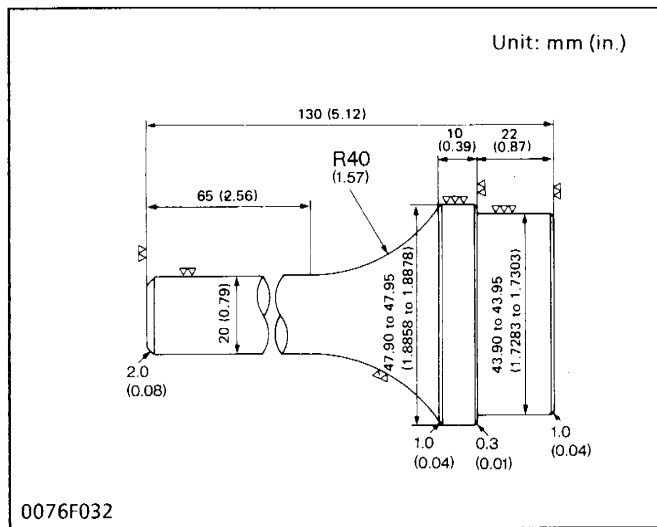

Crankshaft Bearing 1 Replacing Tool

Application: Use to press out and to press fit the crankshaft bearing 1.

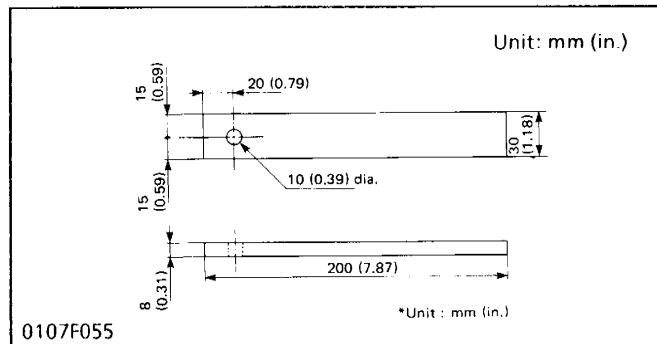

Flywheel Stopper

Application: Use to loosen and tighten the flywheel screw.

1 ENGINE BODY

CHECKING AND ADJUSTING

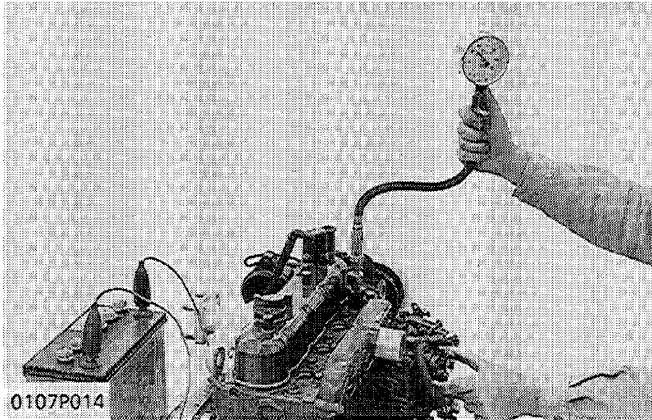

Compression Pressure

1. After warming up the engine, stop it and remove the air cleaner, the muffler and all nozzle holders.
2. Install a compression tester (Code No: 07909-30204) for diesel engines to nozzle holder hole.
3. After making sure that the speed control lever is set at the stop position (Non-injection), run the engine at 200 to 300 min⁻¹(rpm) with the starter.
4. Read the maximum pressure. Measure the pressure more than twice.
5. If the measurement is below the allowable limit, check the cylinder, piston ring, top clearance, valve and cylinder head.

NOTE

- Variances in cylinder compression values should be under 10%.

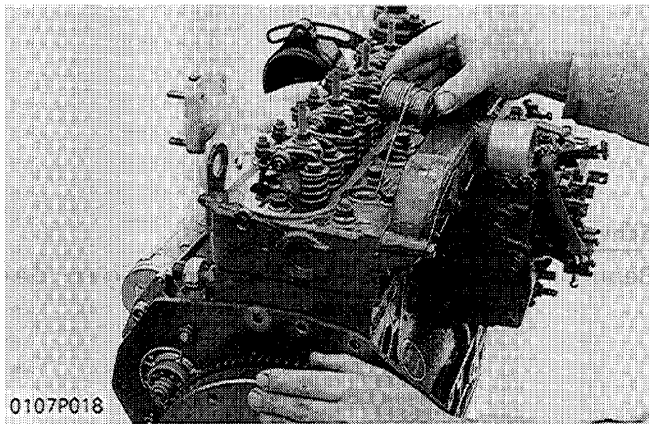

Top Clearance

1. Remove the nozzle holder.
2. Lower the piston in the cylinder.
3. Insert a high quality fuse from the nozzle holder hole on the piston except where it faces the valve or the combustion chamber insert.
4. Rotate the flywheel until the piston is raised and lowered again.
5. Take out the fuse carefully.
6. Repeat three times with a new fuse in the other directions.
7. Measure the thickness of the crushed fuse with vernier calipers.
8. If the measurement is not within the factory specifications, check the oil clearance of the crank pin and clearance between the piston pin and bushing.

(Reference)

- Top clearance (A) can also be got by measuring the projection (C) of the piston from the liner flange, and calculate.

$$\text{Top clearance (A)} = \text{Head Gasket Thickness (B)} - \text{Piston Projection (C)}$$

Head gasket thickness (B) (after retightened)	1.05 to 1.15 mm 0.0413 to 0.0453 in.
Protection (C)	0.25 to 0.55 mm 0.010 to 0.022 in.

- (1) Cylinder Head
(2) Head Gasket
(3) Cylinder Block

- (4) Cylinder Liner
(5) Piston

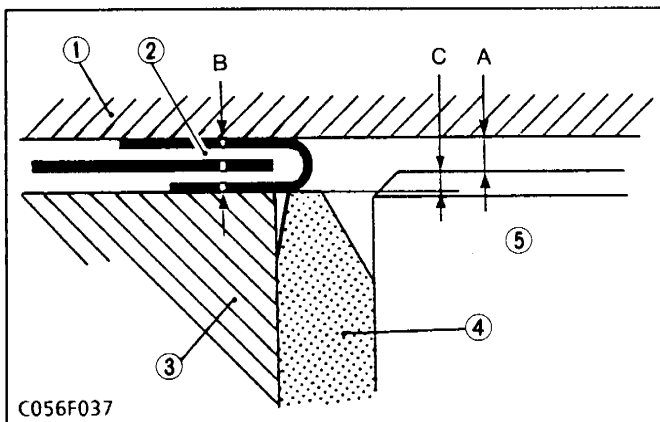

DISASSEMBLING AND ASSEMBLING

[1] DRAINING WATER AND OIL

Draining Cooling Water and Engine Oil

⚠ CAUTION

- Never remove radiator cap until cooling water temperature is below its boiling point. Then loosen cap slightly to the stop to relieve any excess pressure before removing cap completely.
1. Prepare a bucket. Open the drain cock to drain cooling water.
 2. Prepare an oil pan. Remove the drain plug to drain engine oil in the pan.

[2] EXTERNAL COMPONENTS

Air Cleaner and Muffler

1. Remove the air cleaner.
2. Remove muffler retaining nuts to remove the muffler.

(When reassembling)

- Install the muffler gasket so that its steel side face the muffler.

[3] CYLINDER HEAD AND VALVES

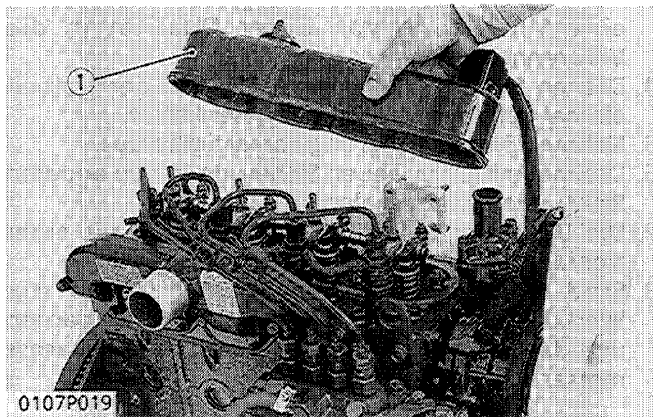

Cylinder Head Cover

1. Remove the cylinder head cover cap nuts.
2. Remove the cylinder head cover (1).

(When reassembling)

- Check to see that the cylinder head cover gasket is not defective.

(1) Head Cover

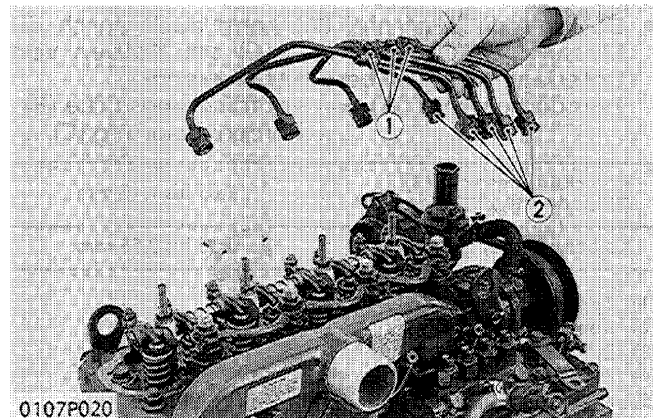

Injection Pipe

1. Loosen the pipe clamps (1).
2. Remove the injection pipes (2).

(1) Pipe Clamps
(2) Injection Pipes

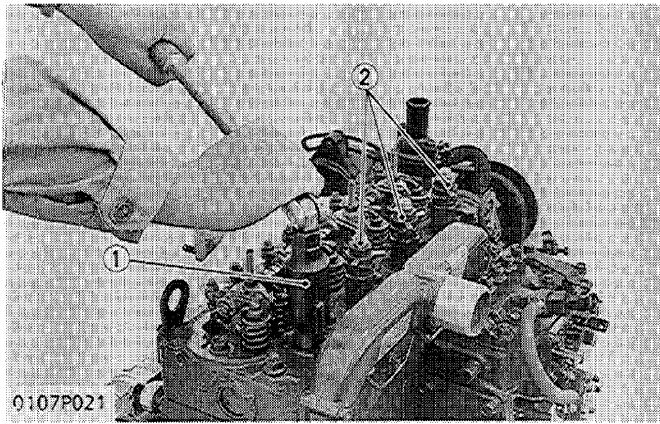

Nozzle Holder Assembly

1. Remove the fuel overflow pipes.
2. Loosen the lock nuts, and remove the nozzle holder assemblies with a nozzle holder socket wrench 27 (1).
3. Remove the copper gaskets on the seats.

- (1) Nozzle Holder Socket Wrench
 (2) Nozzle Holder Assembly

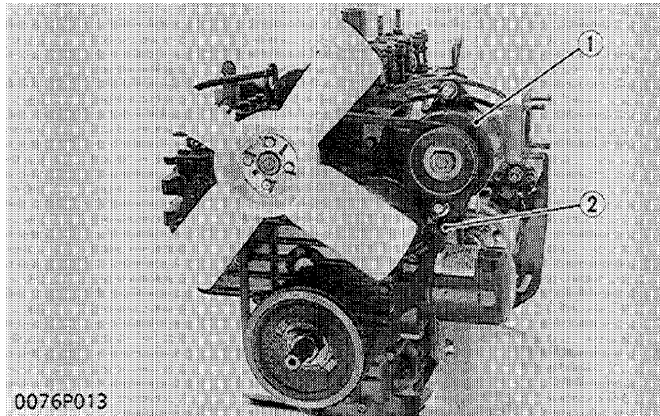

Alternator and Fan Belt

1. Remove the alternator (1).
2. Remove the fan belt (2).

(When reassembling)

- Check to see that there are no cracks on the belt surface.

■ IMPORTANT

- After reassembling the fan belt, be sure to adjust the fan belt tension.

- (1) Alternator
 (2) Fan Belt

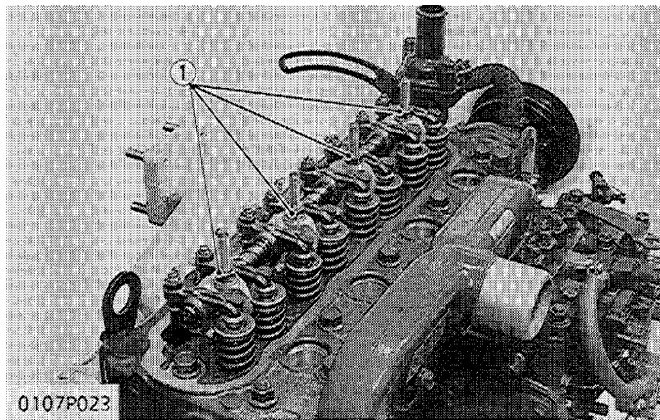

Rocker Arm

1. Remove the rocker arm bracket mounting nuts (1).
2. Remove the rocker arm as a unit.

■ IMPORTANT

- After reassembling the rocker arm, be sure to adjust the valve clearance.

- (1) Rocker Arm Bracket Mounting Nuts

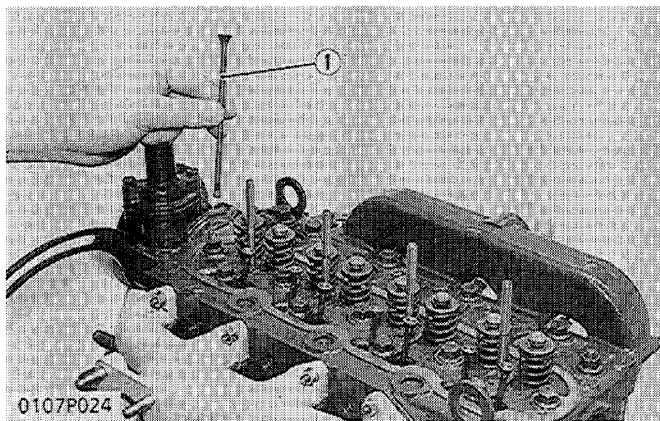

Push Rod

1. Remove the push rods.

(When reassembling)

- When putting the push rods onto the tappets, check to see if their ends are properly engaged with the grooves.

- (1) Push Rod

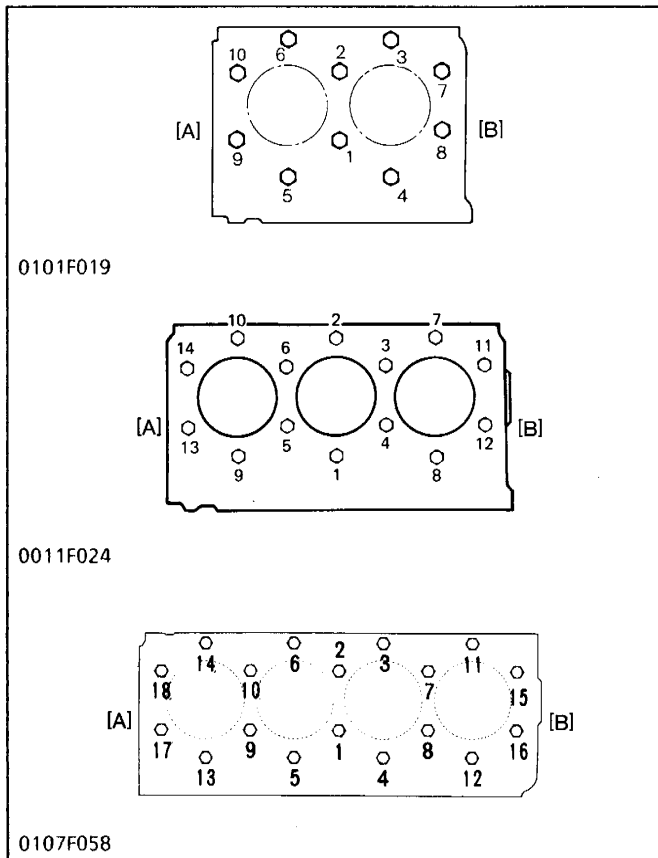

Cylinder Head

1. Loosen the pipe band, and remove the water return pipe.
2. Remove the cylinder head screws and nuts in the order of (10, 14, 18) to (1), and remove the cylinder head.
3. Remove the cylinder head gasket and O-ring.

(When reassembling)

- Replace the head gasket with a new one.
- Install the cylinder head, using care not to damage the O-ring.
- Tighten the cylinder head screws and nuts gradually in the order of (1) to (10, 14, 18) after applying engine oil.
- Retighten the cylinder head screws and nuts after running the engine for 30 minutes.

[A] Gear case side

[B] Flywheel side

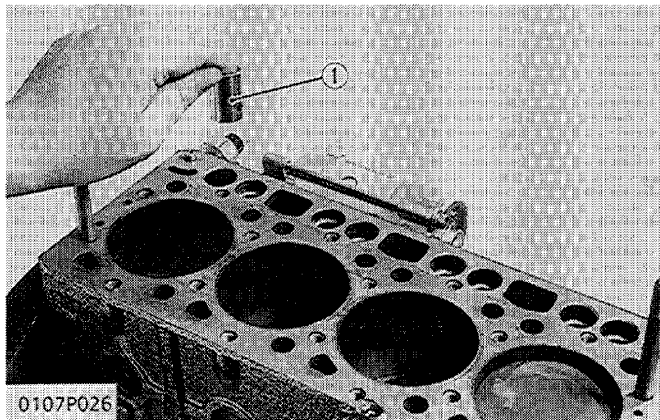

Tappets

1. Remove the tappets from the crankcase.

(When reassembling)

- Before installing the tappets, apply engine oil thinly around them.

■ NOTE

- Mark the cylinder number to the tappets to prevent interchanging.

(1) Tappet

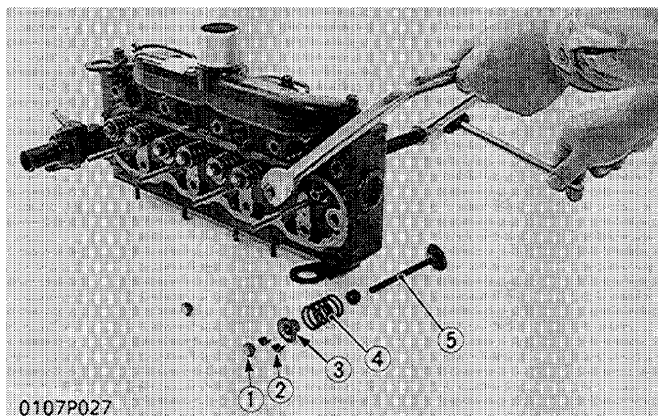

Valves

1. Remove the valve cap (1).
2. Remove the valve spring collet (2) with a valve lifter.
3. Remove the valve spring retainers (3), valve spring (4) and valve (5).

(When reassembling)

- Wash the valve stem and valve guide hole, and apply engine oil sufficiently.
- After installing the valve spring collets, lightly tap the stem to assure proper fit with a plastic hammer.

(1) Valve Cap

(2) Valve Spring Collet

(3) Valve Spring Retainer

(4) Valve Spring

(5) Valve

[4] GEAR CASE

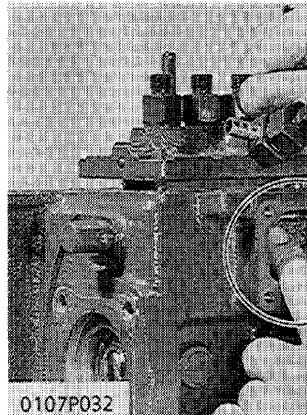
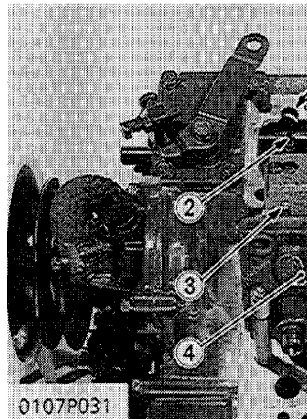
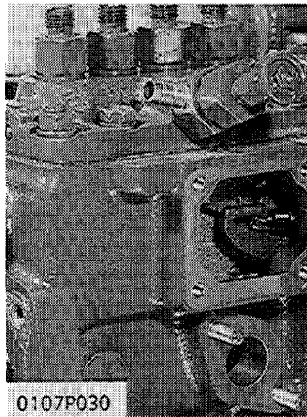
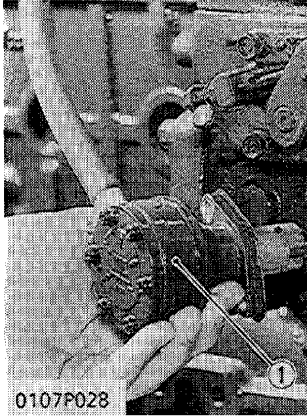

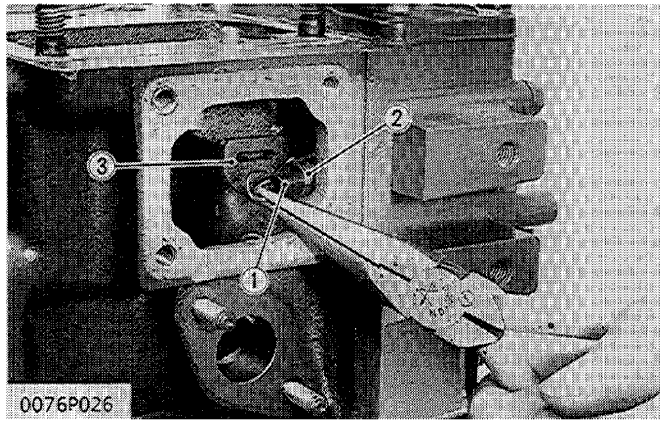

Governor Spring

1. Remove the governor springs 1 (2) and 2 (1) from the fork lever 2 (3).

(When reassembling)

- Fix the governor springs 1 and 2 to the governor lever, and pull the springs through the window of the injection pump, and springs will be able to be hooked on to the governor fork lever 2 with ease.

- (1) Governor Spring 2
- (2) Governor Spring 1
- (3) Fork Lever 2

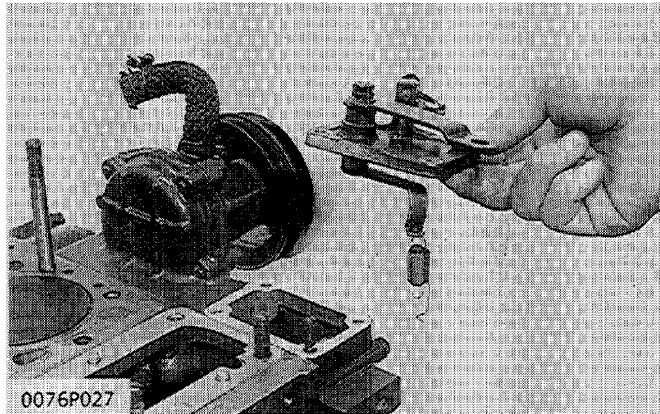

Speed Control Plate

1. Remove the speed control plate with the governor springs 1 and 2.

(When reassembling)

- Be careful not to drop the governor springs 1 and 2 into the gear case.
- Apply a liquid gasket (Three Bond 1215 or equivalent) to both sides of the speed control plate gasket.

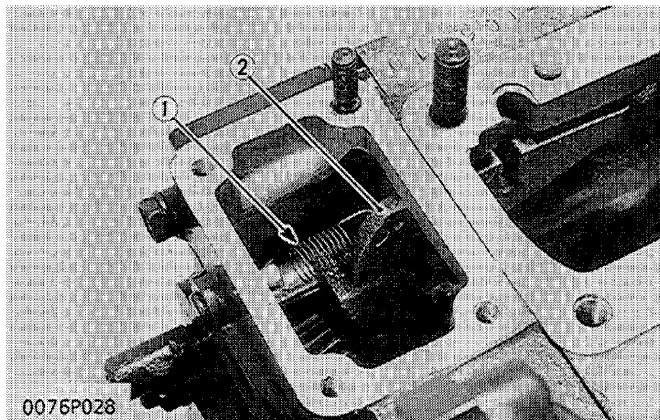

Start Spring

1. Remove the start spring (1) from the fork lever 1 (2).

(When reassembling)

- Be careful not to drop the start spring into the gear case.

- (1) Start Spring
- (2) Fork Lever 1

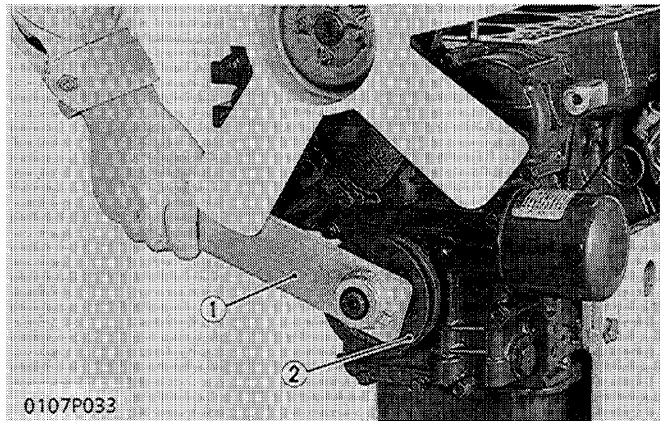

Fan Drive Pulley

1. Flatten the crankshaft washer and remove the crankshaft nut with a socket wrench 29 (1) (Code No: 07916-31841).
2. Pull out the fan drive pulley (2) with a puller.
3. Remove the feather key.

(When reassembling)

- Replace the crankshaft washer with a new one.
- After tightening the crankshaft nut to the specified torque, lock the nut with the crankshaft washer.

- (1) Socket Wrench 29
- (2) Fan Drive Pulley

S.1 ENGINE BOD

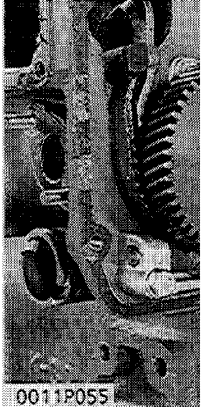
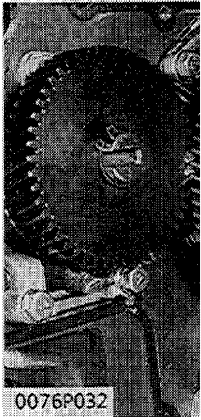
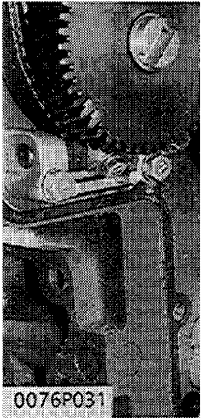
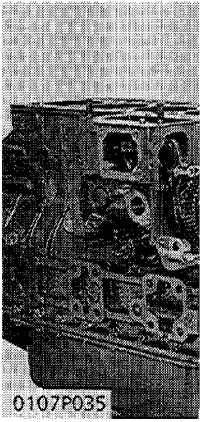

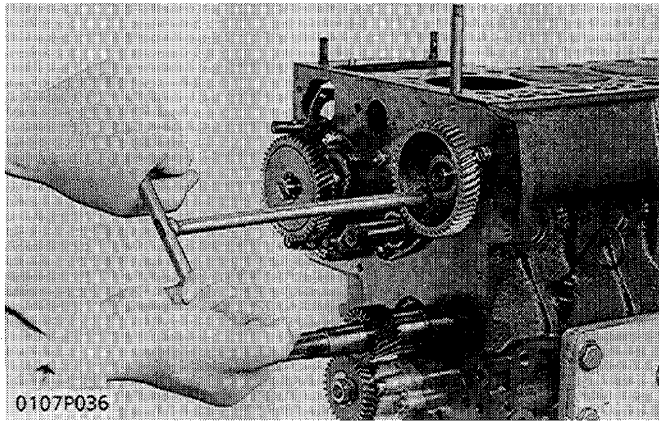

0107P036

Camshaft Stopper Mounting Screw

1. Align the round hole on the cam gear with the camshaft stopper mounting screw position.
2. Remove the camshaft stopper mounting screws.

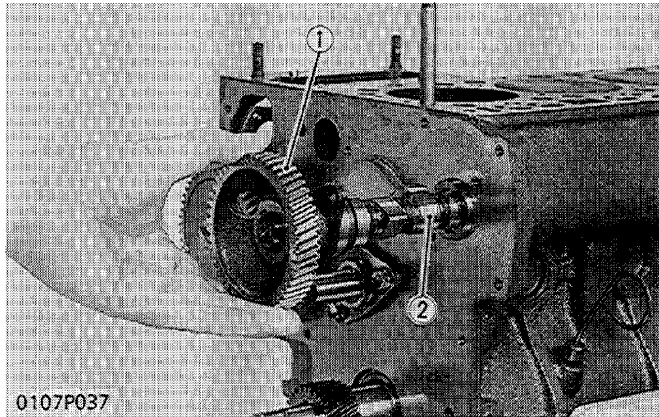

0107P037

Cam Gear and Camshaft

1. Remove the cam gear (1) and camshaft (2).

(When reassembling)

- Apply engine oil thinly to the camshaft before installation.

- (1) Cam Gear
(2) Camshaft

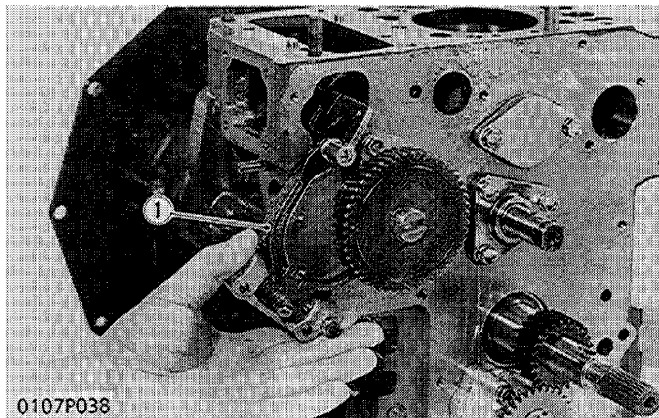

0107P038

Fork Lever Assembly

1. Remove the fork lever holder mounting screws.
2. Remove the fork lever assembly (1).

- (1) Fork Lever Assembly

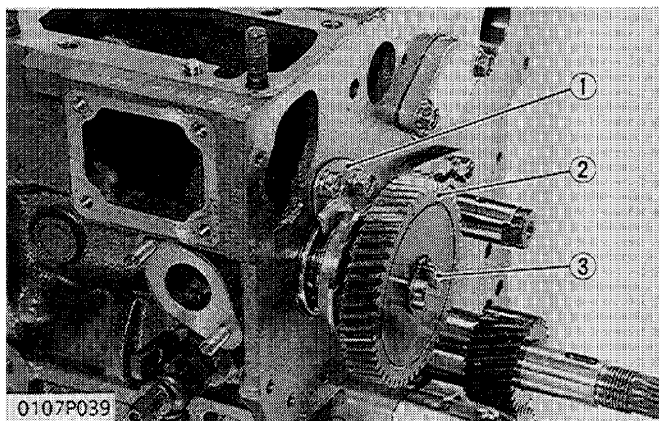

0107P039

Fuel Camshaft

1. Remove the fuel camshaft stopper (1).
2. Remove the fuel camshaft (3) and injection pump gear (2).

(When reassembling)

- Apply engine oil thinly to the fuel camshaft before installation.

- (1) Fuel Camshaft Stopper
(2) Injection Pump Gear
(3) Fuel Camshaft

S.1 ENGINE BODY

[5] PISTON AN

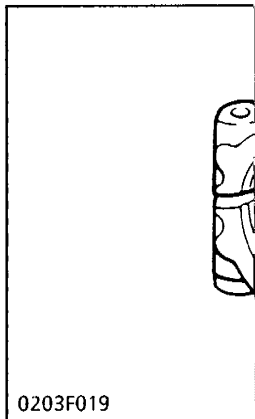
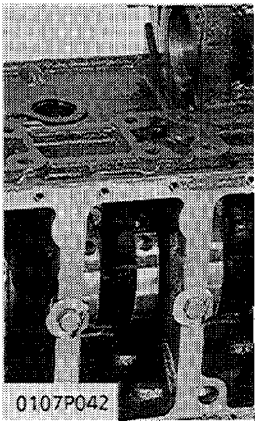
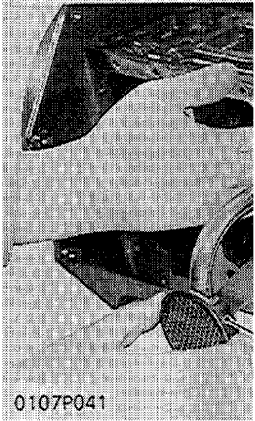
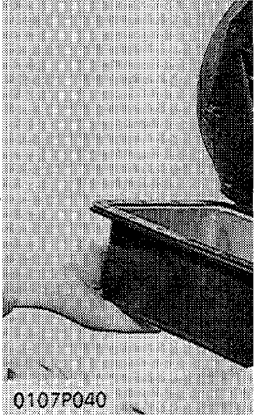

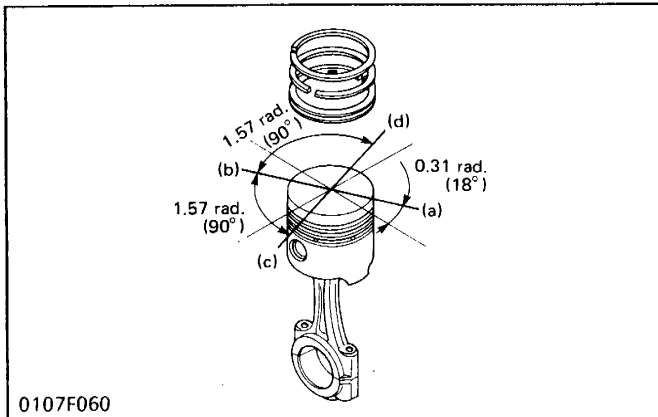
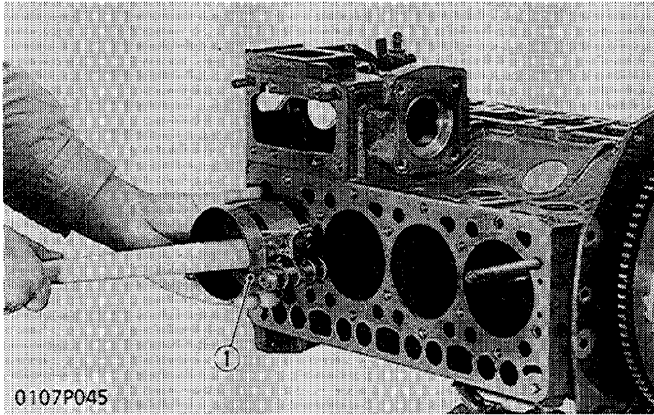
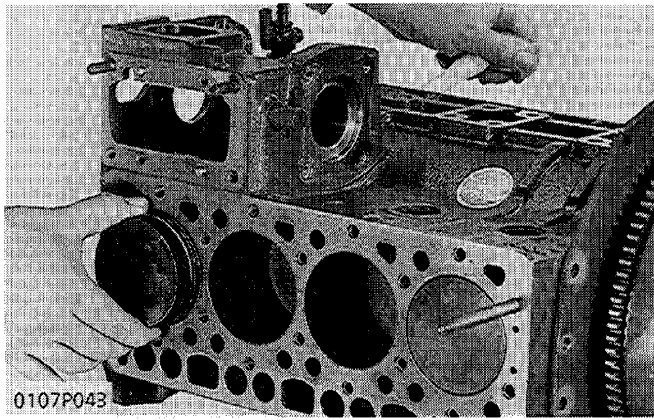

Piston

1. Turn the flywheel, and bring the No.1 piston to the top dead center.
2. Pull out the piston upward by lightly tapping it from the bottom of the crankcase with the grip of a hammer.

(When reassembling)

- Before inserting the piston into the cylinder, apply enough engine oil to the cylinder.
- When inserting the piston into the cylinder, face the mark on the connecting rod to the injection pump.

■ IMPORTANT

- Do not change the combination of cylinder and piston. Make sure of the position of each piston by marking. For example, mark "1" on the No.1 piston.
- When inserting the piston into the cylinder, place the gap of the compression ring 1 on the opposite side of the combustion chamber and stagger the gaps of the compression ring 2 and oil ring making a right angle from the gap of the compression ring 1.
- Carefully insert the pistons using a piston ring compressor (1). Otherwise, their chrome-plated section may be scratched, causing trouble inside the liner.

(1) Piston Ring Compressor

- (a) Combustion Chamber
- (b) Gap of Compression Ring 1
- (c) Gap of Compression Ring 2
- (d) Gap of Oil Ring

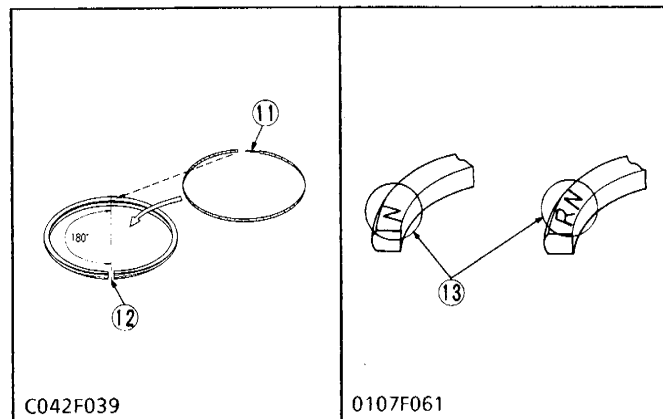
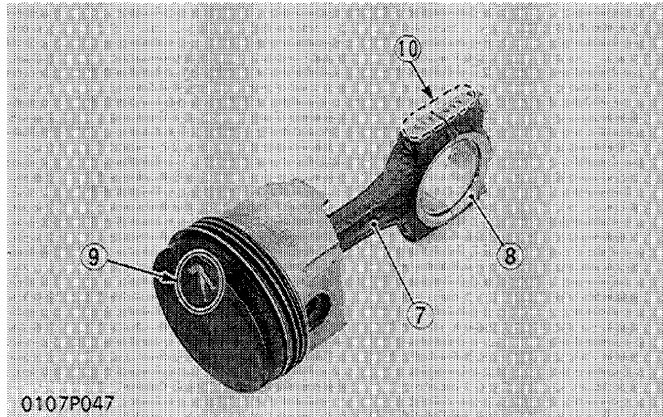
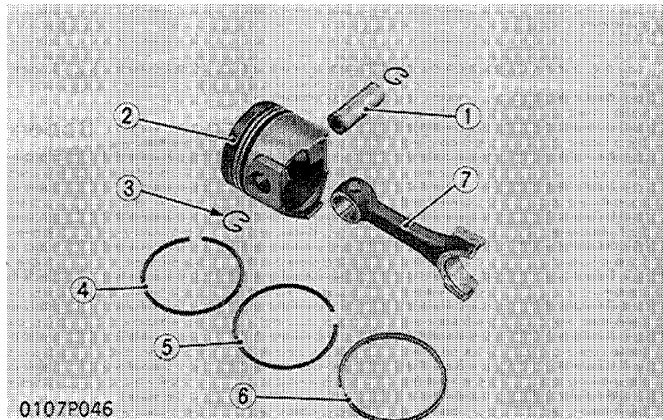

Piston Ring and Connecting Rod

1. Remove the piston rings using a piston ring tool.
2. Put the parting mark (for example, ↑) (9) on the piston head as shown in photograph.
3. Remove the piston pin (1), and separate the connecting rod (7) from the piston (2).

(When reassembling)

- When installing the ring, assemble the rings so that the manufacturer's mark (13) near the gap faces the top of the piston.
- When installing the oil ring onto the piston, place the expander joint (11) on the opposite side of the oil ring gap (12).
- Apply engine oil to the piston pin.
- When installing the piston pin, immerse the piston in 80°C (176°F) oil for 10 to 15 minutes and insert the piston pin to the piston.
- When installing the connecting rod to the piston, align the mark (10) on the connecting rod to the parting mark (9).

■ IMPORTANT

- Mark the same number on the connecting rod and the piston so as not to change the combination.

- (1) Piston Pin
- (2) Piston
- (3) Piston Pin Snap Ring
- (4) Compression ring 1
- (5) Compression Ring 2
- (6) Oil Ring
- (7) Connecting Rod
- (8) Connecting Rod Cap
- (9) parting Mark
- (10) Mark
- (11) Expander Joint
- (12) Oil Ring Gap
- (13) Manufacturer's Mark

[6] FLYWHEEL AND CRANKSHAFT

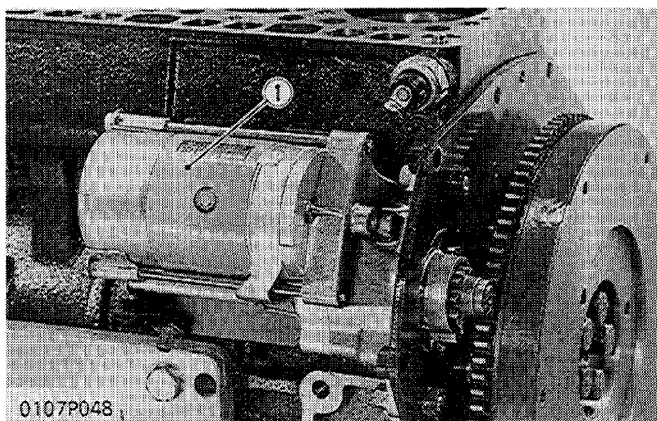

Starter

1. Remove the starter (1).

- (1) Starter

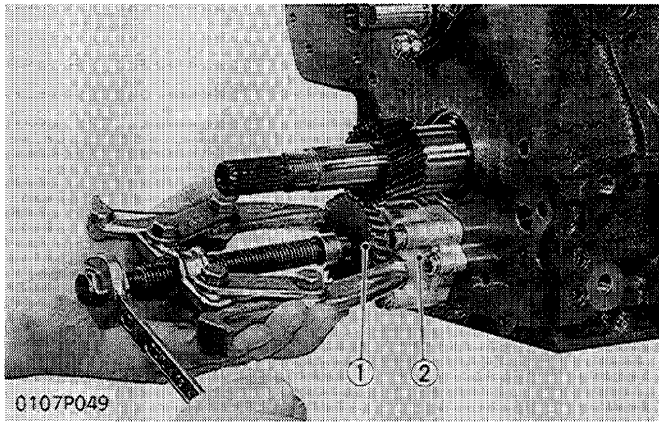

Oil Pump

1. Straighten the claw washer, and remove the nut.
2. Pull out the oil pump drive gear (1) with a puller.
3. Remove the oil pump mounting bolts.
4. Remove the oil pump (2).

- (1) Oil Pump Drive Gear
- (2) Oil Pump

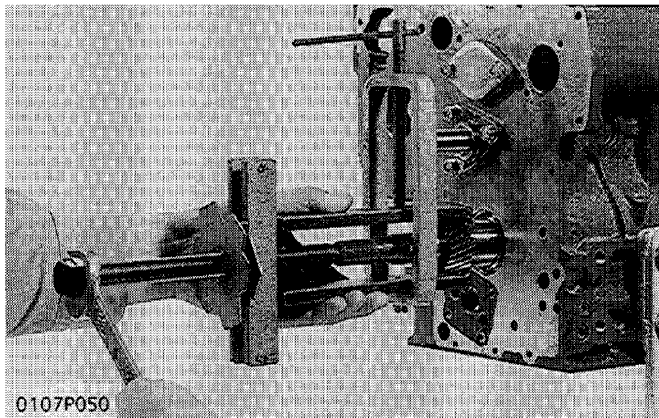

Crank Gear

1. Remove the crank gear with a special-use puller set (Code No: 07916-09032).
2. Remove the feather key on the crankshaft.

(When reassembling)

- Check to see that the feather key is on the crankshaft.
Heat the crank gear to approx. 80°C (176°F), and fit on the crankshaft.

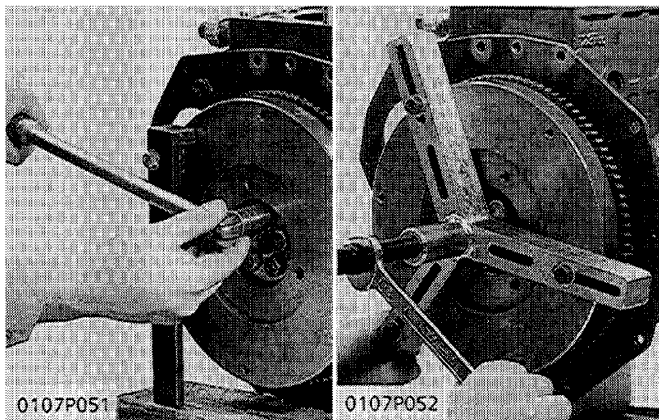

Flywheel

1. Lock the flywheel not to turn using the flywheel stopper.
2. Remove the flywheel screws, except for two which must be loosened and left as they are.
3. Set a flywheel puller (Code No: 07916-32011), and remove the flywheel.

(When reassembling)

- Apply engine oil to the flywheel screws.

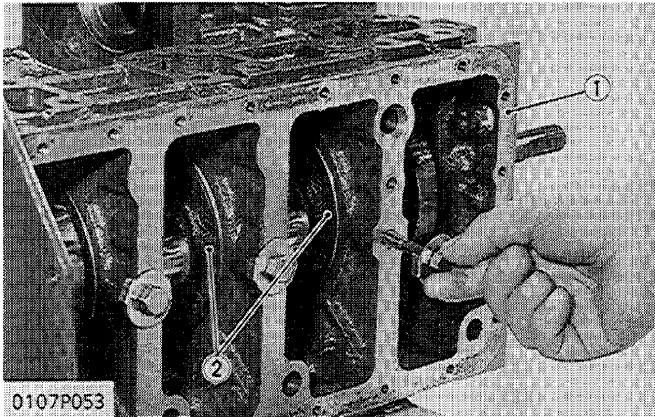
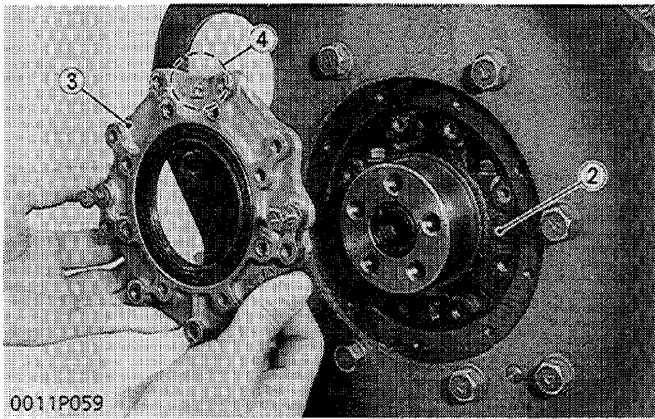

Bearing Case Cover and

■ **NOTE**

- Before disassembling crankshaft. Also check

1. Remove the bearing case cover.
2. Screw two removed screws into the main bearing case cover to secure it.
3. Stretch the washer and screw 2.
4. Pull out the crankshaft.

(When reassembling)

■ **IMPORTANT**

- Install the crankshaft so that the screw hole of main bearing case and screw hole of cylinder block are aligned.
- Apply engine oil to the main bearing case cover and tighten screw 2. After tightening, check the crankshaft rotation firmly.
- Install the bearing case cover so that the casting mark "上" (Up) is facing up.
- Tighten the bearing case cover with even force on the two screws.

- (1) Cylinder Block
- (2) Main Bearing Case 2
- (3) Bearing Case Cover
- (4) Top Mark (上)

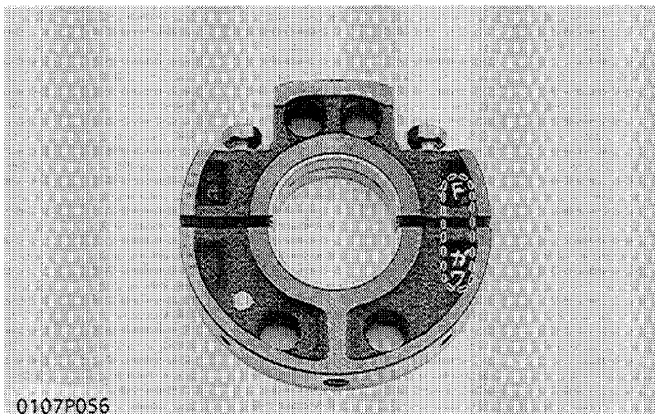
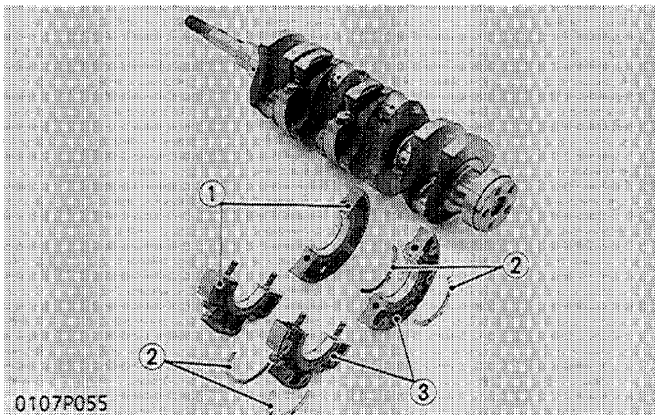

Main Bearing Case Assembly

1. Remove the two screws and remove the main bearing case cover. Be careful with the crankshaft bearing 2.
2. Remove the main bearing case cover as shown above.

(When reassembling)

- Clean the oil passages.
- Apply clean engine oil to the main bearing case cover and thrust bearings.
- Install the main bearing case cover in the original positions. Tighten the screws.
- When installing the main bearing case cover 2, 3, face the mark "上" (Up) facing up.
- Be sure to install the main bearing case cover with the groove facing outward.

- (1) Main Bearing Case Assembly
- (2) Thrust Bearing
- (3) Main Bearing Case Assembly

SERVICING

[1] CYLINDER HEAD

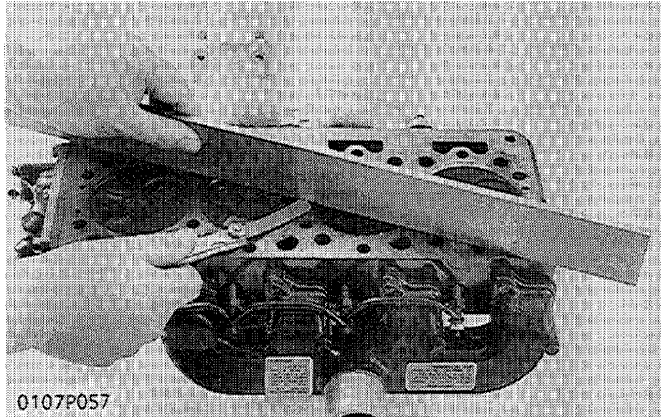

0107P057

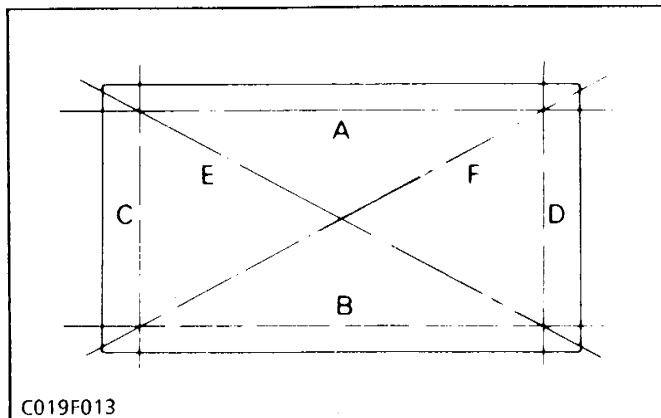

C019F013

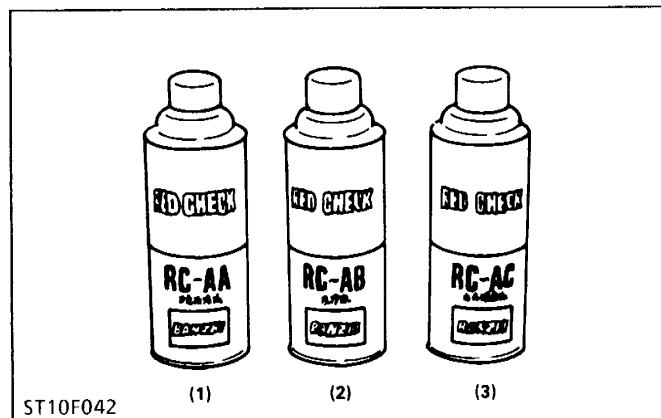

ST10F042

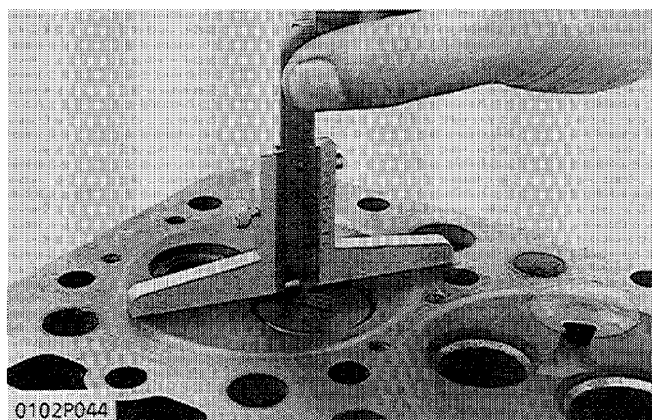

0102P044

Cylinder Head Surface Flatness

1. Thoroughly clean the cylinder head surface.
2. Place a straightedge on the cylinder head's four sides and two diagonal as shown in the figure. Measure the clearance with a feeler gauge.
3. If the measurement exceeds the allowable limit, correct it with a surface grinder.

■ NOTE

- Do not place the straight edge on the combustion chamber.

■ IMPORTANT

- Be sure to check the valve recessing after correcting.

Cylinder Head Flaw

1. Prepare an air spray red check (Code No: 07909-31371).
2. Clean the surface of the cylinder head with detergent (2).
3. Spray the cylinder head surface with the red permeative liquid (1). Leave it five to ten minutes after spraying.
4. Wash away the red permeative liquid on the cylinder head surface with the detergent (2).
5. Spray the cylinder head surface with white developer (3). If flawed, it can be identified as red marks.

Valve Recessing

1. Clean the cylinder head, the valve face and seat.
2. Insert the valve into guide.
3. Measure the valve recessing with a depth gauge.
4. If the measurement exceeds the allowable limit, replace the valve.
If it still exceeds the allowable limit after replacing the valve, correct the valve seat face of the cylinder head with a valve seat cutter (Code No: 07909-33102) or valve seat grinder. Then, correct the cylinder head surface with a surface grinder. Or, replace the cylinder head.

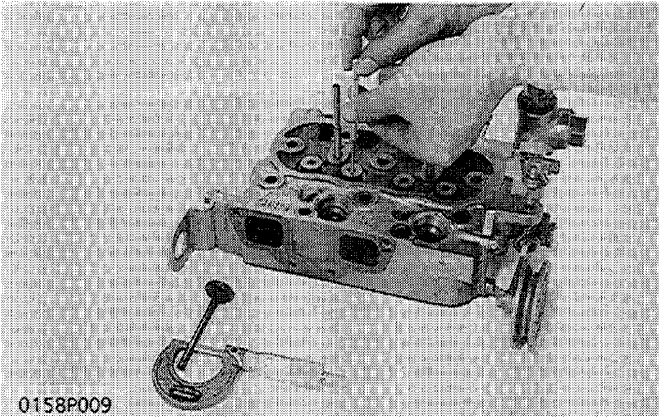

0158P009

Clearance between Valve Stem and guide

1. Remove carbon from the valve guide section.
2. Measure the valve stem O.D. with an outside micrometer.
3. Measure the valve guide I.D. of the cylinder head at the most wear part as shown in the figure below with a small hole gauge. And calculate the clearance.
4. If the clearance exceeds the allowable limit, replace the valves. If it still exceeds the allowable limit, replace the valve guide.

Correcting Valve and Valve Seat

■ NOTE

- Before correcting the valve and seat, check the valve stem and the I.D. of the valve guide section, and repair them if necessary.
- After correcting the valve seat, be sure to check the valve recessing.

1) Correcting Valve

1. Correct the valve with a valve refacer.

2) Correcting Valve Seat

1. Slightly correct the seat surface with a 45° or 30° valve seat cutter (1) (Code No: 07909-33102).
2. Fitting the valve, check the contact position of the valve face and seat surface with red lead. (Visual check) [If the valve is used for a long period of time, it deviates to the upper part of the valve face, causing the seat to contact.]
3. Grind the seat surface with a 15° valve seat cutter so that the valve seat width contacts in the same dimensions from the center of the valve face width.
4. Repeatedly lap the valve and seat until the seated rate is more than 70%.

[A] Check Contact

[B] Correct Seat Width

[C] Check Contact

(a) Identical Dimensions

(b) Valve Seat Width

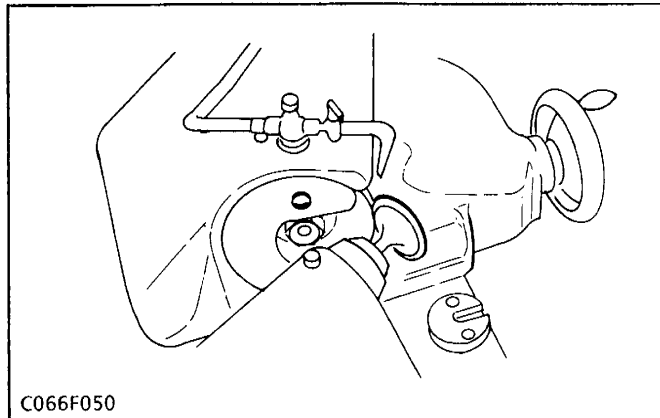

C066F050

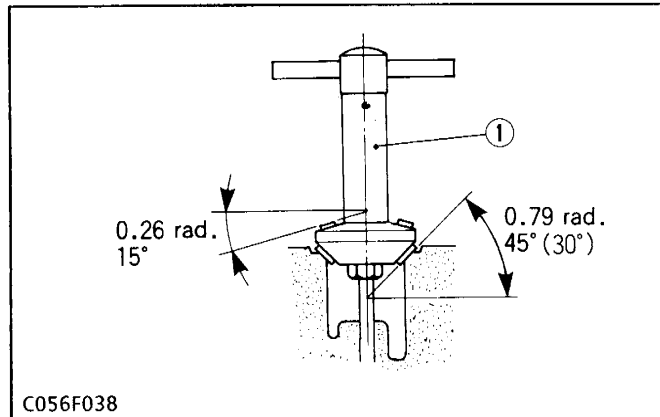

C056F038

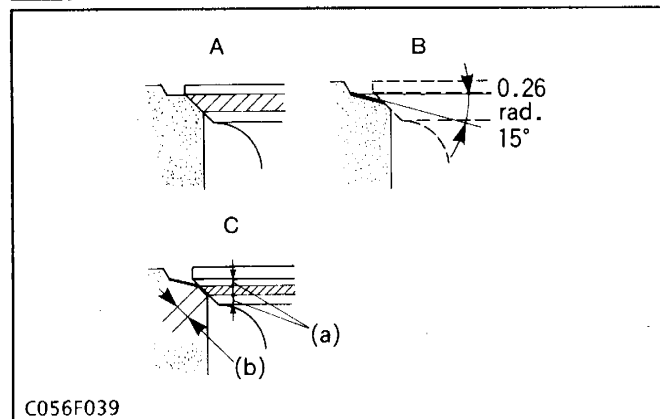

C056F039

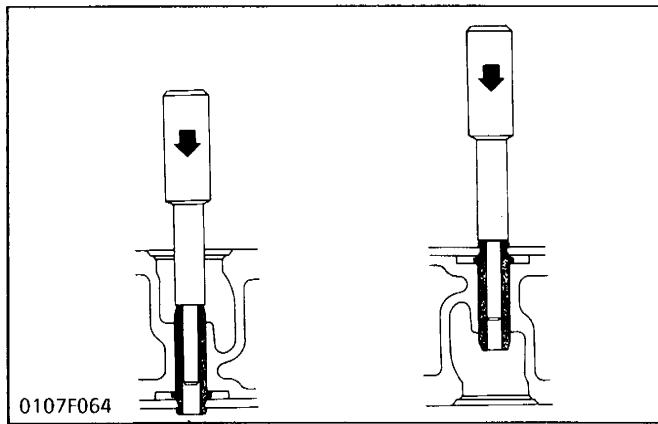

Replacing Valve Guide

1. Press the used valve guide out from the cylinder head's lower side using a valve guide replacing tool.
2. Apply engine oil to the outer surface of the new valve guide, and press fit the valve guide from the cylinder head's upper side until the flange part of the valve guide contacts the cylinder head.
3. After press-fitting, finish the valve guide by means of reaming to dimensions shown in previous table.

NOTE

- Be careful not to strike valve guide with a hammer, etc. during replacement.

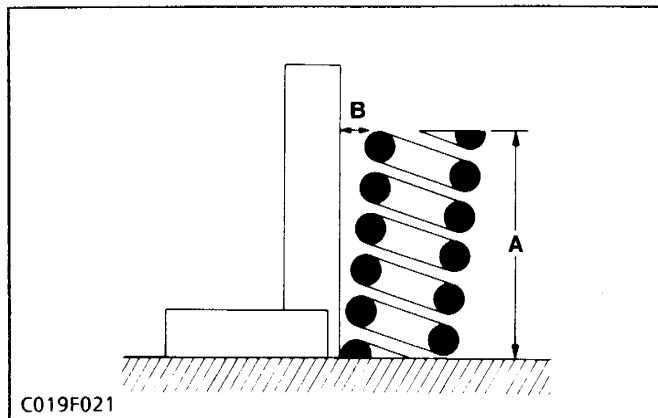

Free Length and Tilt of Valve Spring

1. Measure the length A with vernier calipers. If the measurement is less than the allowable limit, replace.
2. Put the spring on a surface plate, place a square on the side of the spring, and check to see if the entire side is in contact with the square. Rotate the spring and measure the maximum B. If the measurement exceeds the allowable limit, replace.
3. Check the entire surface of the spring for scratches. Replace it, if any.

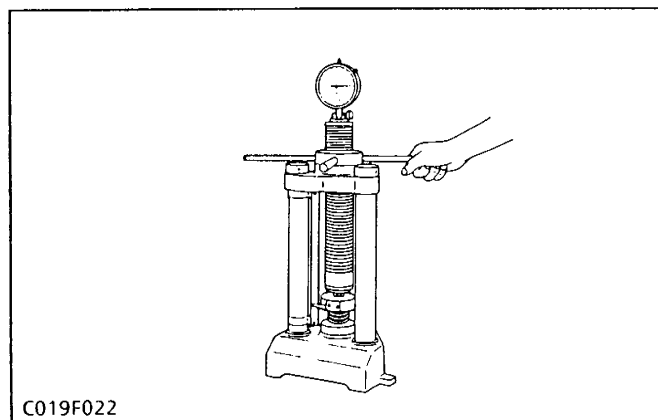

Valve Spring Setting Load

1. Place the spring on a tester and compress it to the same length it is actually compressed in the engine.
2. Read the compression load on the gauge.
3. If the measurement exceeds the allowable limit, replace it.

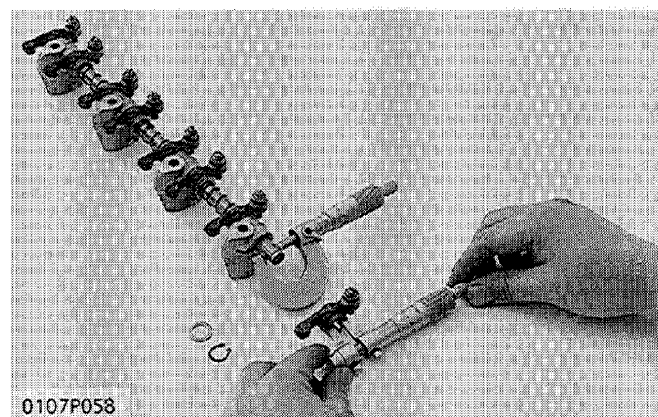

Oil Clearance of Rocker Arm Shaft and Bearing

1. Measure the rocker arm bearing I.D. with an inside micrometer.
2. Measure the rocker arm shaft O.D. with an outside micrometer, and then calculate the oil clearance.
3. If the clearance exceeds the allowable limit, replace the rocker arm and measure the oil clearance again. If it still exceeds the allowable limit, replace also the rocker arm shaft.

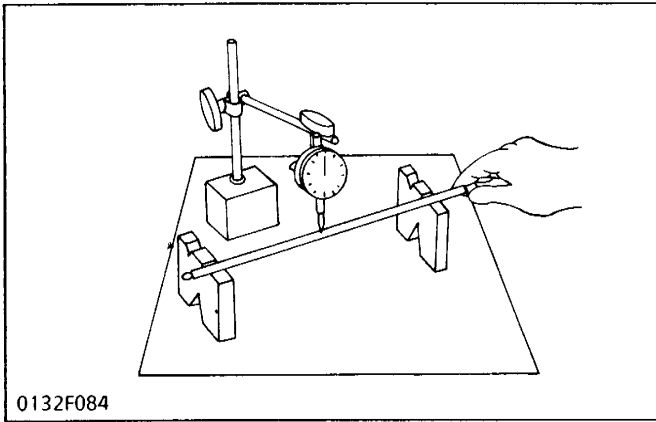

Push Rod Alignment

1. Check the both end of the push rod for cracks, damage and unusual wear.
2. Measure the bending of the push rod with a dial indicator.
3. If the measurement exceeds the allowable limit, replace the push rod.

[2] TIMING GEAR AND CAMSHAFT

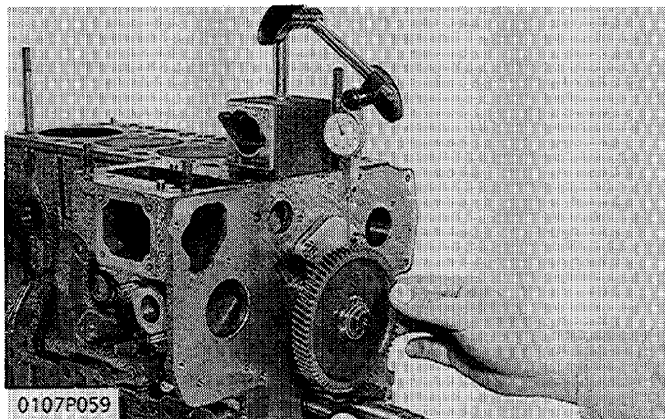

Timing Gear Backlash

1. Set a dial indicator (lever type) with its tip on the gear tooth.
2. Move the gear to measure the backlash, holding its mating gear.
3. If the backlash exceeds the allowable limit, check the oil clearance of the shafts and gear.
4. If the oil clearance is proper, replace the gear.

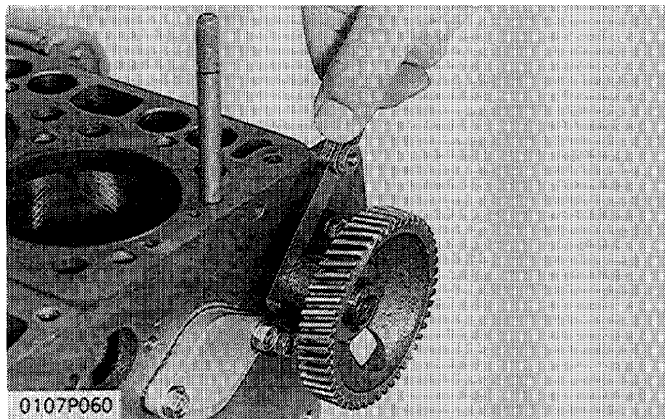

End Play of Camshaft

1. Pull the cam gear with the camshaft to its end.
2. Measure the clearance between the cam gear and camshaft stopper.
3. If the clearance exceeds the allowable limit, replace the camshaft stopper.

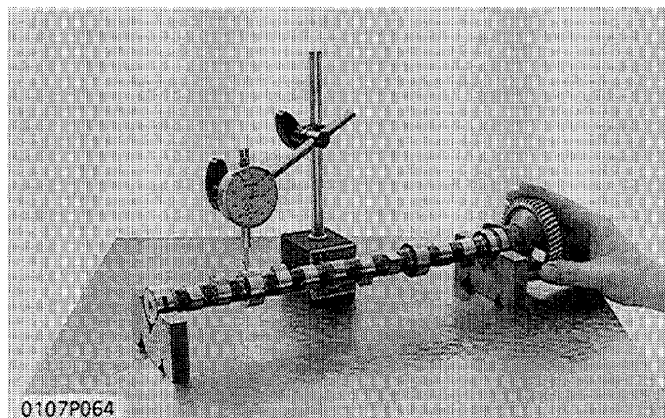

Camshaft Alignment

1. Support the camshaft with V-blocks on the surface plate and set a dial indicator with its tip on the intermediate journal at right angle.
2. Rotate the camshaft on the V-blocks and get the misalignment (half of the measurement).
3. If the misalignment exceeds the allowable limit, replace the camshaft.

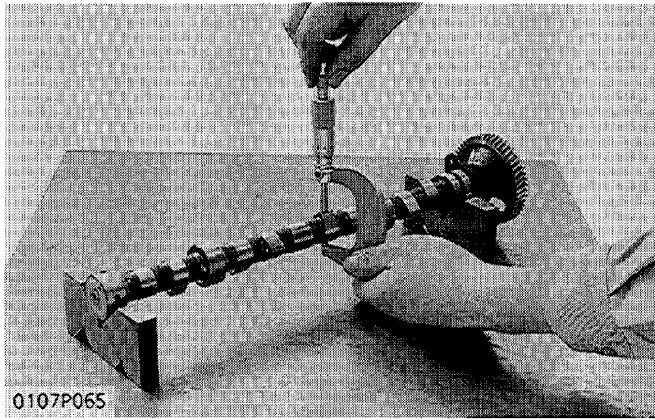

Intake and Exhaust Cam Height

1. Measure the height of the cam at its highest point with an outside micrometer.
2. If the measurement is less than the allowable limit, replace it.

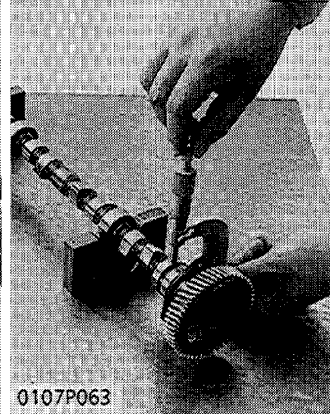
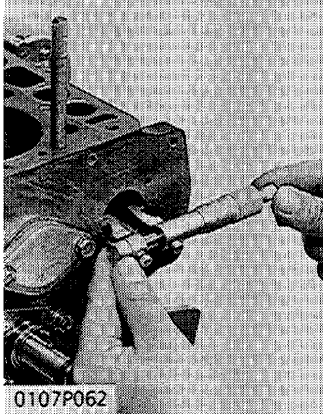

Oil Clearance of Camshaft Journal

1. Measure the camshaft journal O.D. with an outside micrometer.
2. Measure the cylinder block bore I.D. for camshaft with an inside micrometer. Calculate the oil clearance.
3. If the clearance exceeds the allowable limit, replace the camshaft.

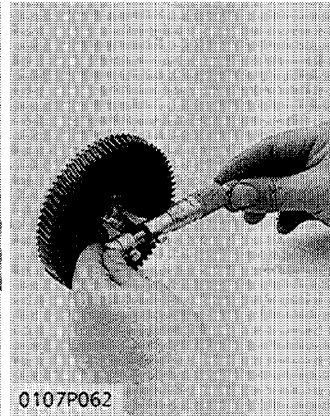
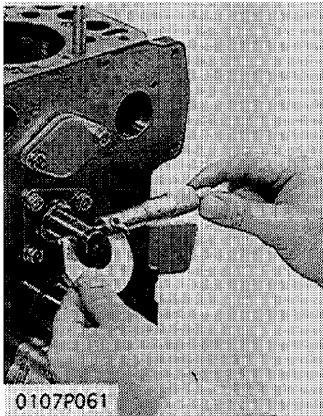

Clearance between Idle Gear Shaft and Idle Gear Bushings

1. Measure the idle gear shaft O.D. with an outside micrometer.
2. Measure the idle gear bushings I.D. with an inside micrometer, and calculate the clearance.
3. If the clearance exceeds the allowable limit, replace the bushing.

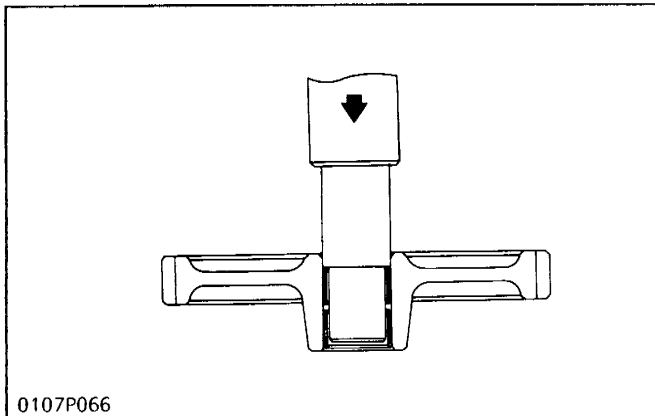

Replacing Idle Gear Bushings

1. Press the used bushings out using an idle gear bushing replacing tool.
2. Press fit new bushings.

[3] PISTON AND CONNECTING ROD

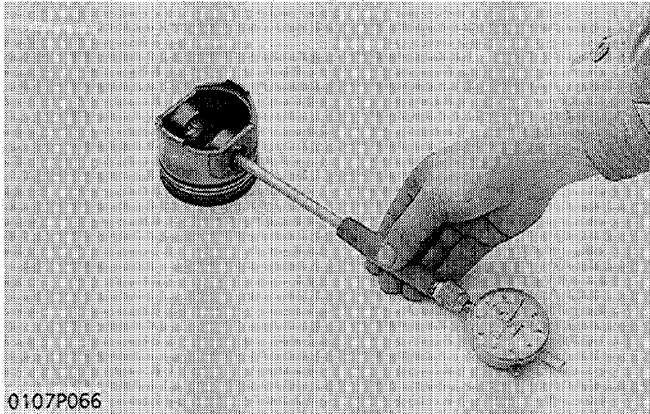

0107P066

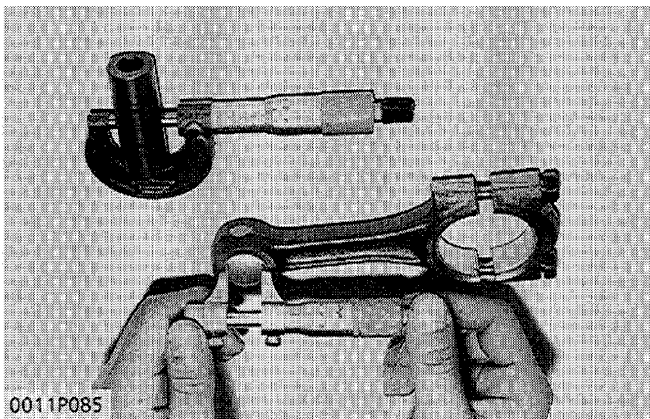

0011P085

Piston Pin-Bore I.D.

1. Measure the I.D. of the piston pin-bore in both the horizontal and vertical directions with a cylinder gauge.
2. If the measurement exceeds the allowable limit, replace the piston.

Oil Clearance between Piston Pin and Small End

Bushing

1. Measure the O.D. of the piston pin where it contacts the bushing with an outside micrometer.
2. Measure the I.D. of the piston pin bushing at the connecting rod small end with a cylinder gauge. Calculate the oil clearance.
3. If the clearance exceeds the allowable limit, replace the bushing. If it still exceeds the allowable limit, replace the piston pin.

Replacing Connecting Rod Small End Bushing

(When removing)

1. Press out the small end bushing with a connecting rod small end bushing replacing tool.

(When installing)

1. Clean a new small end bushing and bore, and apply engine oil to them.
2. Insert a new bushing onto the tool and press-fit it with a press so that the seam (1) of bushing positions as shown in the figure, until it is flush with the connecting rod.
3. Drill a hole to the bushing with aligning the oil hole (2) of connecting rod using 4.0 mm dia. (0.157 in. dia.) drill.

■ NOTE

- Be sure to chamfer the oil hole circumference with an oil stone.

[Service parts dimension]

Oil clearance between piston pin and small end bushing	Factory spec.	0.015 to 0.075 mm 0.00059 to 0.00295 in.
	Allowable limit	0.15 mm 0.0059 in.

(1) Seam

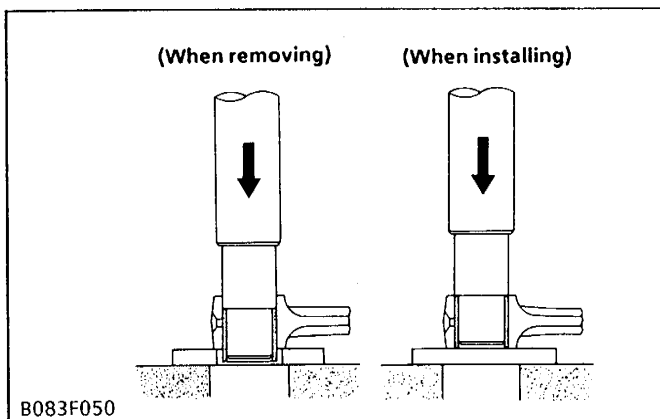

B083F050

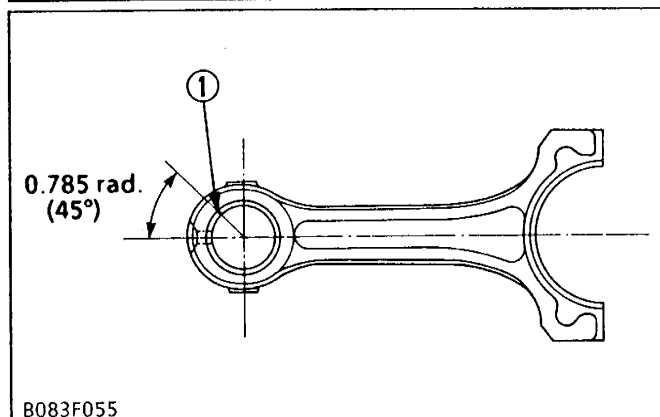

B083F055

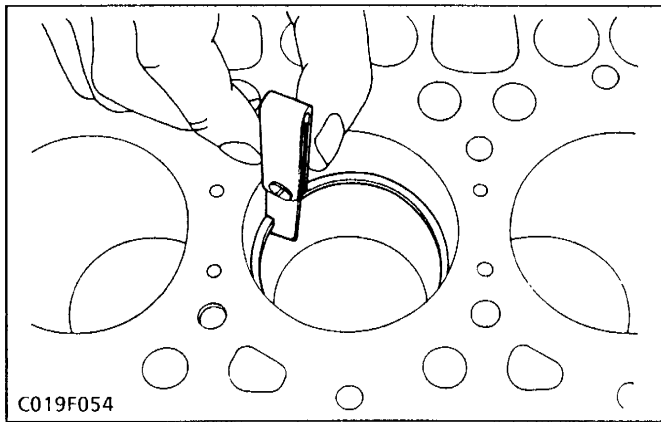

Piston Ring Gap

1. Insert the piston ring into the lower part of the liner (the least worn out part) with the piston.
2. Measure the ring gap with a feeler gauge.
3. If the gap exceeds the allowable limit, replace the ring.

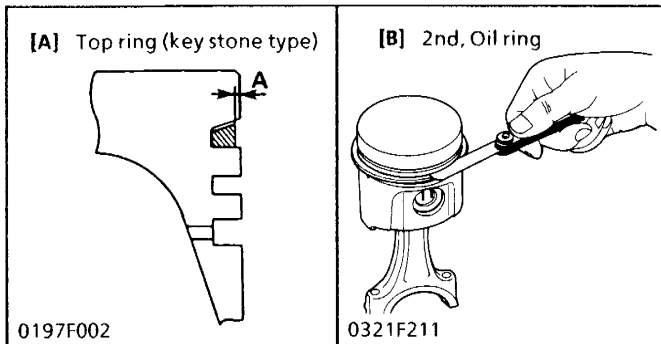

Clearance between Piston Ring and Groove

1. Remove carbon from the ring grooves.
2. Measure the clearance between the ring and the groove with a feeler gauge or depth gauge.
3. If the clearance exceeds allowable limit, replace the ring since compression leak and oil shortage result.
4. If the clearance still exceeds the allowable limit after replacing the ring, replace the piston.

Factory specification : A	More than 0.2 mm
---------------------------	------------------

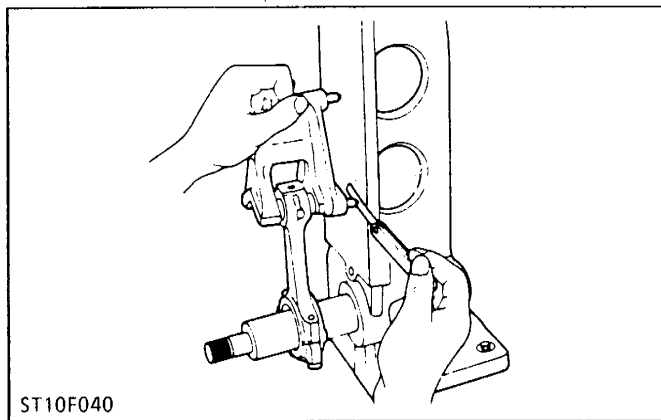

Connecting Rod Alignment

■ NOTE

- Since the I.D. of the connecting rod small end bushing is the basis of this check, check the bushing for wear beforehand.

1. Install the piston pin into the connecting rod.
2. Install the connecting rod on the connecting rod alignment tool (Code No: 07909-31661).
3. Put a gauge over the piston pin and move it against the face plate.
4. If the gauge does not fit squarely against the face plate, measure the space between the pin of the gauge and the face plate.
5. If the measurement exceeds the allowable limit, replace the connecting rod.

[4] CRANKSHAFT

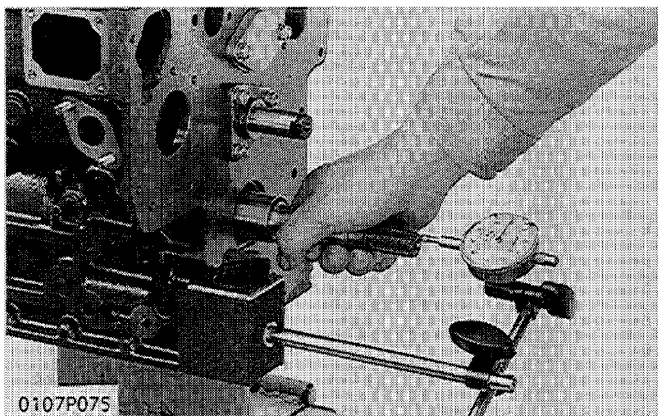

End Play of Crankshaft

1. Move the crankshaft to the flywheel side.
2. Set a dial indicator to the crankshaft.
3. Measure the end play by pulling the crankshaft toward the crank gear.
4. If the measurement exceeds the allowable limit, replace the thrust bearings.

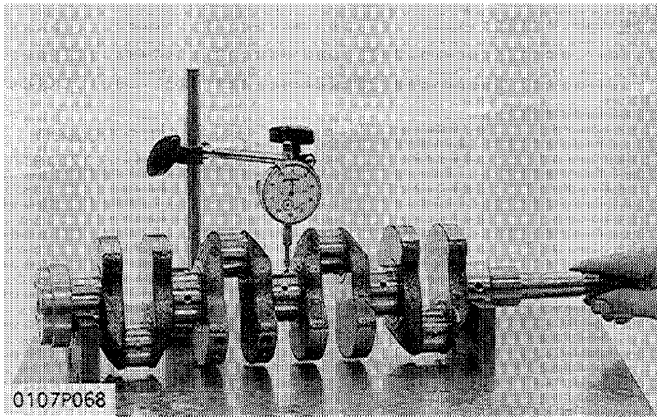

Crankshaft Alignment

1. Support the crankshaft with V-blocks on the surface plate and set a dial indicator with its tip on the intermediate journal at right angle.
2. Rotate the crankshaft on the V-blocks and get the misalignment (half of the measurement).
3. If the misalignment exceeds the allowable limit, replace the crankshaft.

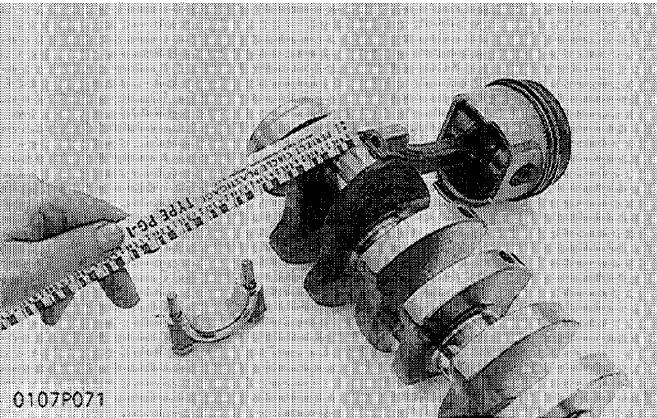

Oil Clearance between Crank Pin and Crank Pin

Bearing

1. Clean the crank pin and crank pin bearing.
2. Put a strip of press gauge (Code No: 07909-30241) on the center of the crank pin in each direction as shown in the figure.

■ IMPORTANT

- Never insert the press gauge into the crank pin oil hole.

3. Install the connecting rod cap and tighten the screws to the specified torque, and remove the cap again.

■ NOTE

- Fasten the crankshaft so that it does not turn.

4. Measure the amount of the flattening with the scale and get the oil clearance.
5. If the clearance exceeds the allowable limit, replace the bearing.

(Reference)

- When the oil clearance is to be measured by removing the crankshaft, tighten the connecting rod cap with the specified torque, then measure the crank pin bearing I.D. with a cylinder gauge or an inside micrometer. And measure the crank pin O.D. with an outside micrometer. Calculate the oil clearance.

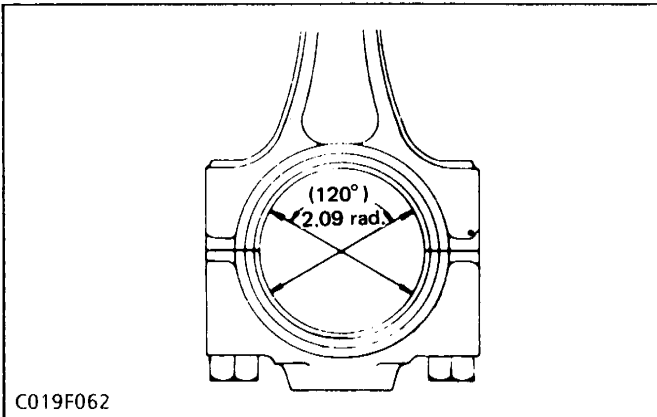

Crankshaft Sleeve Wear and Replacing Crankshaft

Sleeve

1. Measure the wear of the crankshaft sleeve using a surface roughness tester.
2. If the measurement exceeds the allowable limit, replace the crankshaft sleeve.
3. Remove the used crankshaft sleeve using a special-use puller set (Code No:07916-09032).

(When installing)

4. Set the sleeve guide C (2) to the crankshaft.

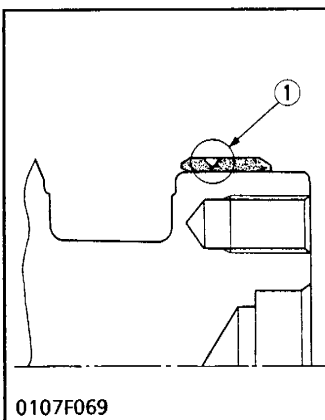

0107F069

(1) Wear

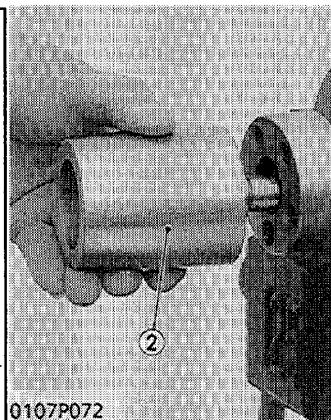

0107P072

(2) Sleeve Guide C

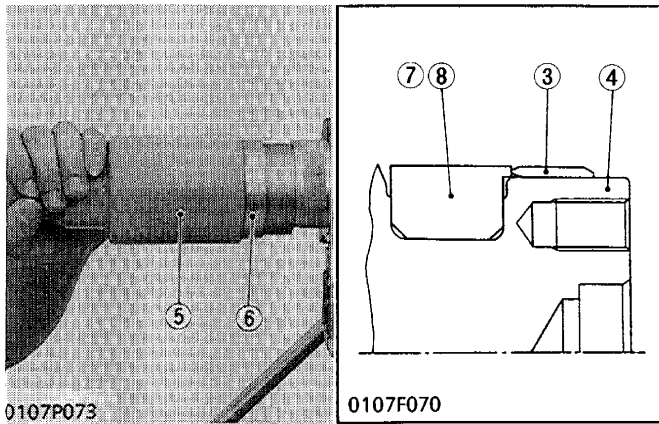

5. Set the stopper C (7) to the crankshaft as shown in figure.
6. Heat a new sleeve to a temperature between 150 and 200°C (302 and 392°F), and fix the sleeve to the crankshaft as shown in figure.
7. Press fit the sleeve using the auxiliary socket for pushing (5).

- | | |
|----------------------------------|--------------------|
| (3) Crankshaft Sleeve | (6) Sleeve Guide B |
| (4) Crankshaft | (7) Stopper B |
| (5) Auxiliary Socket for Pushing | (8) Stopper C |

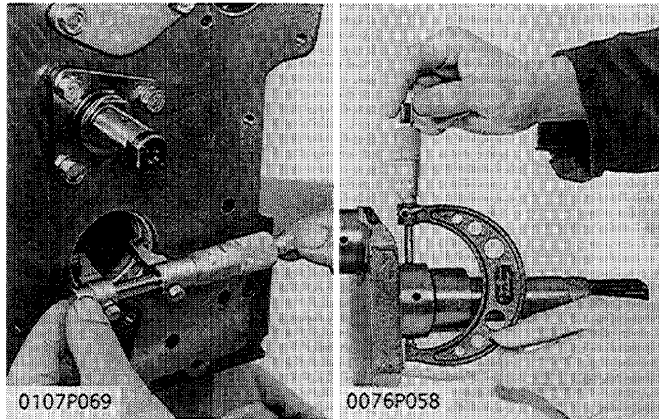

Oil Clearance between Crankshaft Journal and Crankshaft Bearing 1

1. Measure the O.D. of the crankshaft journal with an outside micrometer.
2. Measure the I.D. of the crankshaft bearing 1 with an inside micrometer. Calculate the oil clearance.
3. If the clearance exceeds the allowable limit, replace the crankshaft bearing 1.

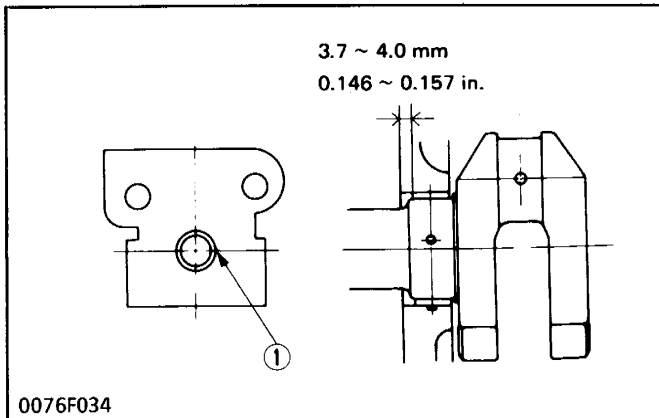

Replacing Crankshaft Bearing 1

(When removing)

1. Press out the bearing 1 with crankshaft bearing 1 replacing tool.

(When installing)

1. Clean a new bearing 1 and bore, and apply engine oil to them.
2. Press fit a new bearing 1 using an inserting tool, taking due care to see that the seam of bearing 1 faces the exhaust manifold side.

- (1) Seam

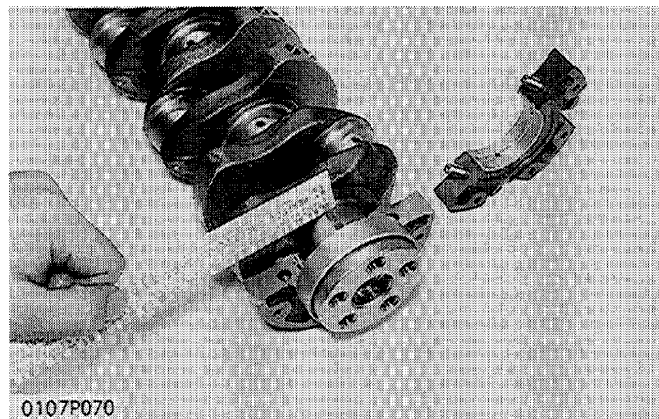

Oil Clearance between Crankshaft Journal and Crankshaft Bearing 2 (3, 4, 5)

1. Clean the crankshaft journal and crankshaft bearing.
2. Put a strip of press gauge (Code No: 07909-30241) on the center of the journal.

■ IMPORTANT

- Never insert the press gauge into the oil hole of the journal.
3. Install the main bearing case and tighten the screws to the specified torque, and remove the cases again.
 4. Measure the amount of the flattening with the scale and get the oil clearance.
 5. If the clearance exceeds the allowable limit, replace the crankshaft bearing.

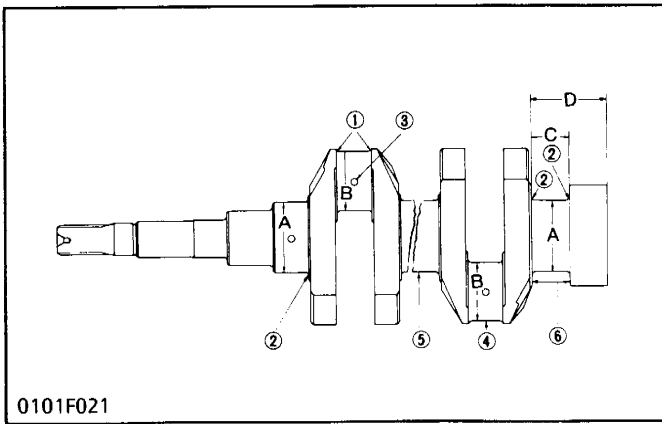

0101F021

Undersized and Oversized Bearing

If the standard-size bearing cannot be employed due to excessive wear of the crankpin and crank journal, employ undersize or oversize bearings.

For under size or oversize bearing use, follow the precautions noted below.

1. Grind the crankpin corner (1) and journal corner (2) with a wheel which has specified round corner and width without shoulder.
 - ① 3.3 to 3.7 mm (0.1300 to 0.1457 in.)
 - ② 2.8 to 3.2 mm (0.1102 to 0.1260 in.)
2. Be sure to chamfer the oil hole circumference (3) to 1 to 1.5 mm (0.04 to 0.06 in.) radius with an oil stone.
3. The crankpin (4) must be fine-finished to higher than ∇∇∇∇ (0.4-S).
4. The crank journal (5) must be fine-finished to higher than ∇∇∇∇ (0.4-S).
5. The crank journal side surface (C) must be fine-finished to higher than ∇∇∇∇ (0.4-S).

		Dimension D
Overize	+0.2 mm +0.008 in.	48.1 to 48.3 mm 1.894 to 1.902 in.
Overize	+0.4 mm +0.016 in.	48.3 to 48.5 mm 1.902 to 1.909 in.

Size	Code No.	Name of bearing	Bearing mark	Crankshaft processing dimension	
-0.2 mm -0.008 in.	15261-2391-1	Crankshaft bearing 1 (0.2 minus)	020 US	A	43.734 to 43.750 mm 1.7218 to 1.7224 in.
-0.2 mm -0.008 in.	15261-2393-1	Crankshaft bearing 2 (0.2 minus)	020 US		
-0.4 mm -0.016 in.	15261-2392-1	Crankshaft bearing 1 (0.4 minus)	040 US		43.534 to 43.550 mm 1.7140 to 1.7145 in.
-0.4 mm -0.016 in.	15261-2394-1	Crankshaft bearing 2 (0.4 minus)	040 US		
-0.2 mm -0.008 in.	15531-2297-1	Crank pin bearing (0.2 minus)	020 US	B	36.759 to 36.775 mm 1.4473 to 1.4478 in.
-0.4 mm -0.016 in.	15531-2298-1	Crank pin bearing (0.4 minus)	040 US		36.559 to 36.575 mm 1.4394 to 1.4399 in.
+0.2 mm +0.008 in.	15261-2395-1	Thrust bearing 1 (0.2 plus)	020 OS	C	24.40 to 24.45 mm 0.9763 to 0.9783 in.
	15261-2397-1	Thrust bearing 2 (0.2 plus)			
+0.4 mm +0.016 in.	15261-2396-1	Thrust bearing 1 (0.4 plus)	040 OS		24.80 to 24.85 mm 0.9763 to 0.9783 in.
	15261-2398-1	Thrust bearing 2 (0.4 plus)			

[5] CYLINDER

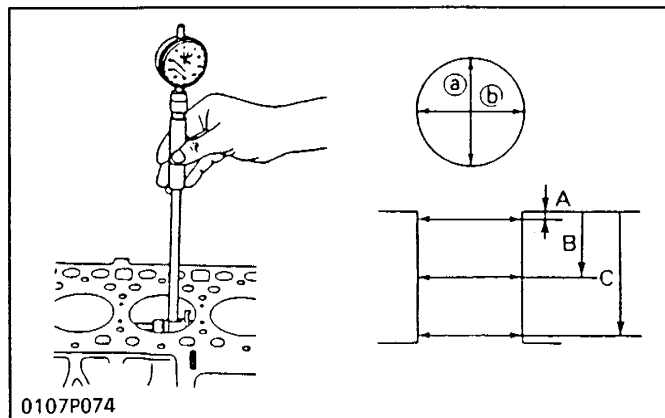

- 0107P074
- A : Approx. 20 mm (0.787 in.)
 - B : Approx. 40 mm (1.575 in.)
 - C : Approx. 100 mm (3.937 in.)
 - a : Right-angled to Piston Pin
 - b : Piston Pin Direction

Cylinder Wear

1. Measure the I.D. of the cylinder at the six positions (See figure) with a cylinder gauge to find the maximum and minimum I.D.'s.
2. Get the difference (Maximum wear) between the maximum and the minimum I.D.'s.
3. If the wear exceeds the allowable limit, bore and hone to the oversize dimension.
4. Visually check the cylinder wall for scratches. If deep scratches are found, the cylinder should be bored.

Cylinder I.D.	Factory spec.	D650-B	64.000 to 64.019 mm 2.5394 to 2.5204 in.
		Z500-B, D750-B	68.000 to 68.019 mm 2.6772 to 2.6779 in.
		Z600-B, ZH600-B D850-B, DH850-B V1100-B, VH1100-B	72.000 to 72.019 mm 2.8346 to 2.8353 in.
		D950-B, V1200-B	75.000 to 75.019 mm 2.9528 to 2.9535 in.
Maximum wear		Allowable limit	0.15 mm 0.0059 in.

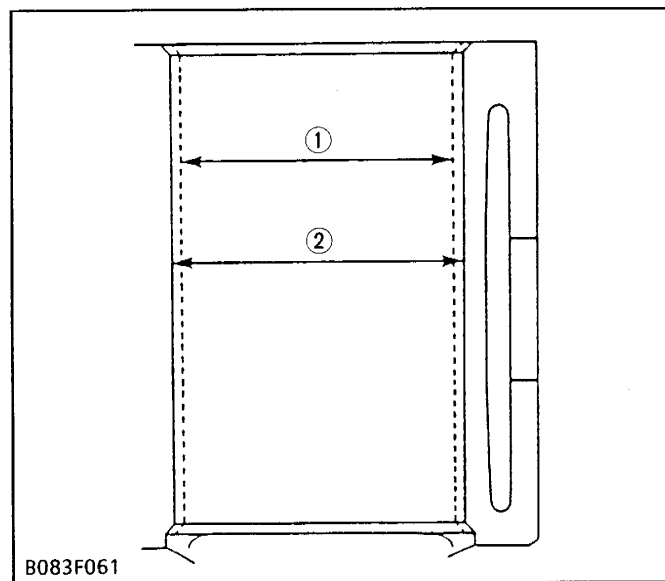

- B083F061
- (1) Cylinder I.D. (Before Correction)
 - (2) Oversize Cylinder I.D.

Correcting Cylinder

1. When the cylinder is worn beyond the allowable limit, bore and hone it to the specified dimension.

(Oversize Cylinder I.D.)

Factory spec.	D650-B	64.500 to 64.519 mm' 2.5394 to 2.5401 in.	
	Z500-B, D750-B	68.500 to 68.519 mm 2.6969 to 2.6976 in.	
	Z600-B, ZH600-B D850-B, DH850-B V1100-B, VH1100-B	72.500 to 72.519 mm 2.8543 to 2.8551 in.	
	D950-B, V1200-B	75.500 to 75.519 mm 2.9724 to 2.9732 in.	
Maximum wear		Allowable limit	0.15 mm 0.0059 in.
Finishing		Hone to 1.2 to 2.0 μR max. ∇∇∇ (0.000047 to 0.000079 in. R max.)	

2. Replace the piston and piston rings with oversize ones. (Make reference to a parts list)

■ IMPORTANT

- When the oversize cylinder is worn beyond the allowable limit, the conventional cylinder liner can be installed for servicing.

■ NOTE

- When the oversize cylinder is worn beyond the allowable limit:

[Type with liner]

Replace the cylinder liner for servicing in accordance with items 2, 3, and 4 under "Cylinder Liner Installation".

[Liner-less type]

Replace the cylinder block, or install the cylinder liner for servicing in accordance with each item under "Cylinder Liner Installation".

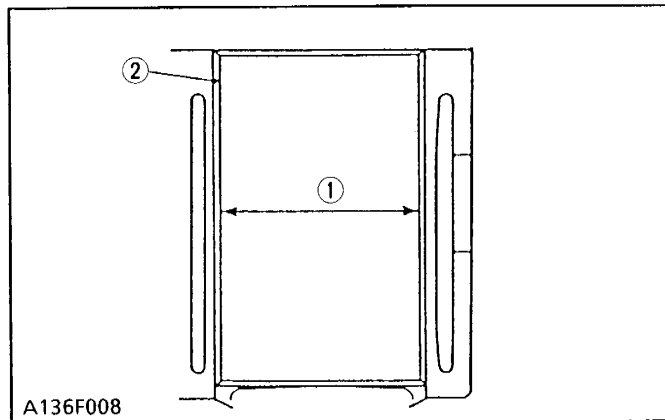
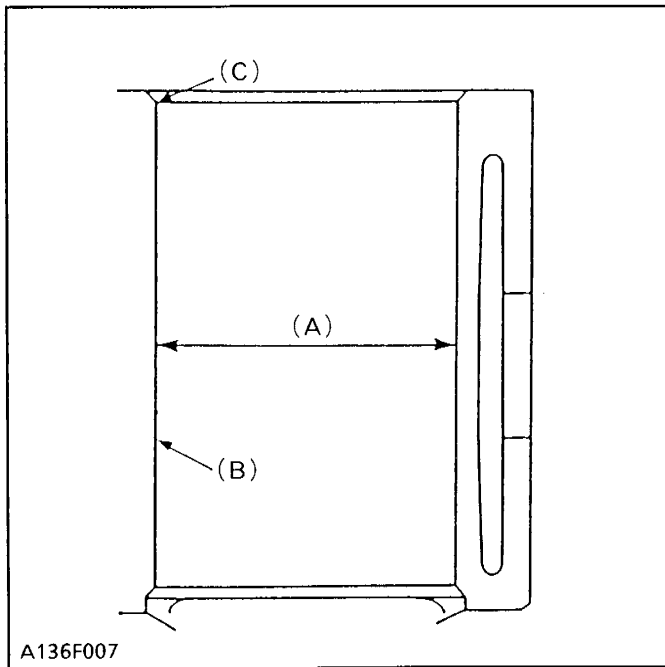

(1) Cylinder I.D. (After finishing) (2) Cylinder Liner

Cylinder Liner Installation

■ NOTE

- The cylinder liner is used only when wear of the liner-less type engine cylinder exceeds 0.5 mm (0.0197 in.).

- Bore and finish the crankcase cylinder to the dimension specified below.

Factory spec. (A)	D650-B	67.000 to 67.019 mm 2.6378 to 2.6385 in.
	Z500-B, D750-B	71.000 to 71.019 mm 2.7953 to 2.7960 in.
	Z600-B, ZH600-B D850-B, DH850-B V1100-B, VH1100-B	75.000 to 75.019 mm 2.9528 to 2.9535 in.
Finishing (B)	Allowable limit	6.3 μm R max. 0.000248 in. R max.
Chamfer the upper cylinder area to (c)		C0.1 to C0.2 mm C0.0039 to C0.0079 in.

- Clean matching surface of the liner and crankcase cylinder then apply the engine oil.
- Press in the cylinder liner into the crankcase cylinder in position.
- Bore and hone to finish the cylinder liner to the dimension specified below. Install the standard piston and piston ring.

Factory spec.	D650-B	64.000 to 64.019 mm 2.5197 to 2.5204 in.
	Z500-B, D750-B	68.000 to 68.019 mm 2.6772 to 2.6779 in.
	Z600-B, ZH600-B D850-B, DH850-B V1100-B, VH1100-B	72.000 to 72.019 mm 2.8346 to 2.8353 in.
	D950-B, V1200-B	75.000 to 75.019 mm 2.9528 to 2.9535 in.
Hone to		1.2 to 2 μR max. 0.0000472 to 0.000079 in. R max.

2 LUBRICATING SYSTEM

CHECKING

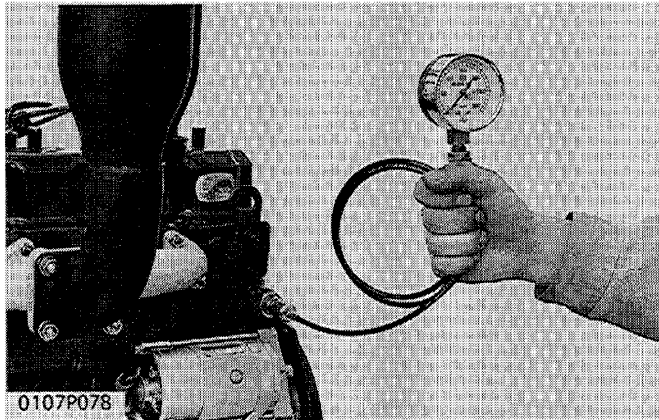

Engine Oil Pressure

1. Remove the oil switch and set a pressure tester (Code No: 07916-32031).
2. Start the engine. After warming up, measure the oil pressure of both idling and rated speeds.
3. If the oil pressure is less than the allowable limit, check the following.
 - Engine oil insufficient
 - Oil pump defective
 - Oil strainer clogged
 - Oil gallery clogged
 - Excessive oil clearance of bearing
 - Foreign matter in the relief valve

DISASSEMBLING AND ASSEMBLING

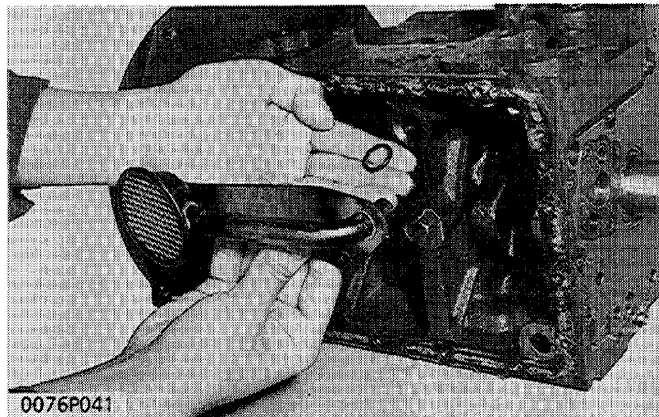

Oil Strainer

1. Detach the oil pan by lightly tapping the groove of the pan with a wooden hammer.
2. Remove the mounting bolt of oil filter.
3. Detach oil filter 1, being careful of the O-ring.

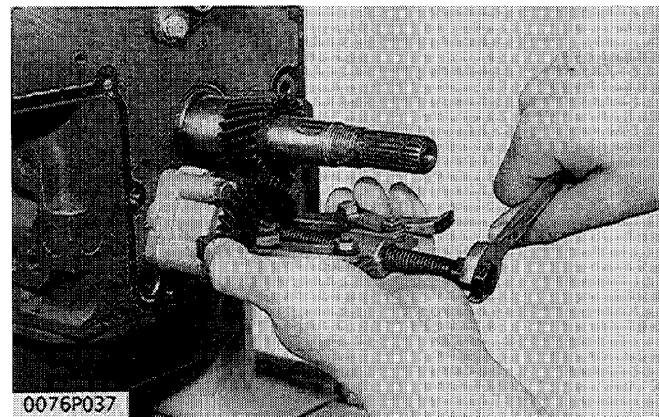

Oil Pump

1. Straighten the claw of the claw washer of the oil pump, and remove the nut.
2. Draw out the oil pump drive gear with gear puller.
3. Remove the four oil pump mounting bolts. Detach the oil pump.

SERVIZII

[1] OIL PU

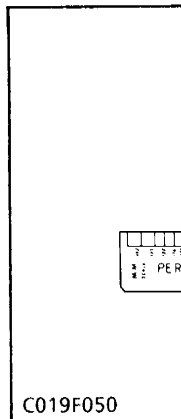
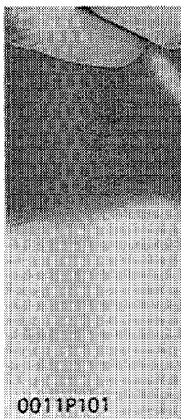

3 COOLING SYSTEM

CHECKING

[1] FAN BELT

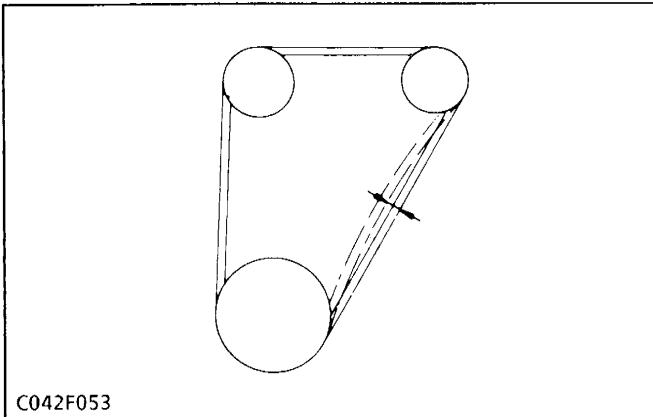

Fan Belt Tension

1. Press the fan belt between fan pulley and pulley at force of 10 kgf (98N, 22 lbs). Check if the fan belt deflection is 10 to 12 mm (0.394 to 0.472 in.).
2. If the deflection is not within the factory specifications, adjust with the tension pulley adjusting nut.

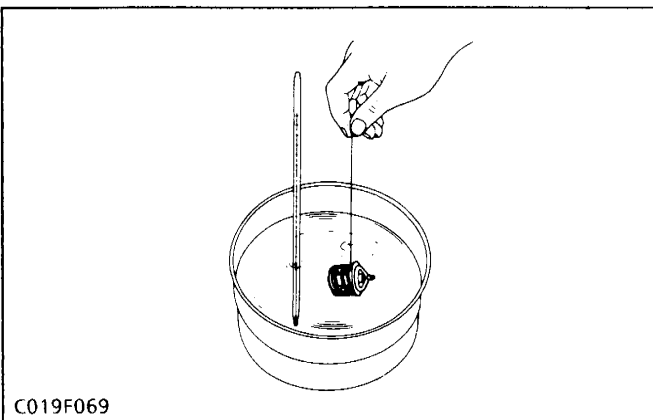

Thermostat's Valve Opening Temperature

1. Push down the thermostat valve and insert a string between the valve and the valve seat.
2. Place the thermostat and a thermometer in a container with water and gradually heat the water.
3. Hold the string to suspend the thermostat in the water. When the water temperature rises, the thermostat valve will open, allowing it to fall down from the string. Read the temperature at this moment on the thermometer.
4. Continue heating the water and read the temperature when the valve has risen by about 6 mm (0.236 in.).
5. If the measurement is not acceptable, replace the thermostat.

Thermostat's valve opening temperature	Factory spec.	69.5 to 72.5°C 157.1 to 162.5°F
Temperature at which thermostat completely opens	Factory spec.	85°C 185°F

[2] RADIATOR

! CAUTION

- When removing the radiator cap, wait at least ten minutes after the engine has stopped and cooled down. Otherwise, hot water may gush out, scalding nearby people.

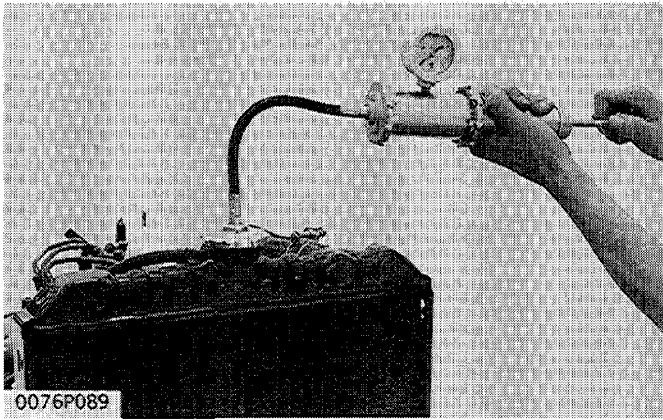

0076P089

Radiator Water Leakage

1. Pour a specified amount of water into the radiator.
2. Set a radiator tester (Code No: 07909-31551). Increase water pressure to the specified pressure of 137 kPa (1.4 kgf/cm², 20 psi).
3. Check each section for water leakage.
4. When water leakage is excessive, replace the radiator. If water leakage is caused by a small pinhole, correct the radiator with radiator cement.

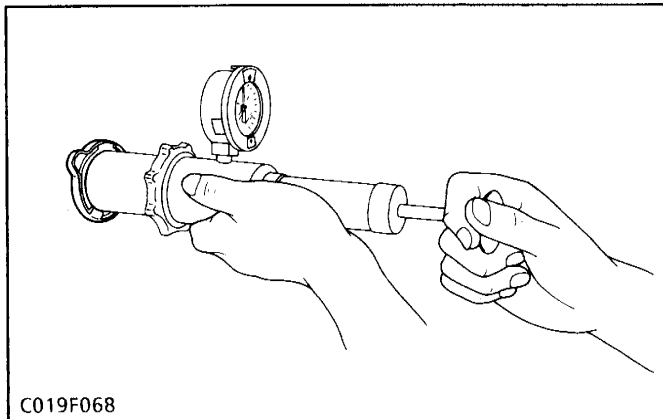

C019F068

Radiator Cap Air Leakage

1. Set a radiator tester (Code No: 07909-31551) to the radiator cap.
2. Apply the specified pressure of 98.1 kPa (0.9 kgf/cm², 12.8 psi).
3. Check if the pressure drop to less than 0.6 kgf/cm² (59 kPa, 9 psi) in 10 seconds.
4. If the pressure is less than the factory specification, replace it.

DISASSEMBLING AND ASSEMBLING

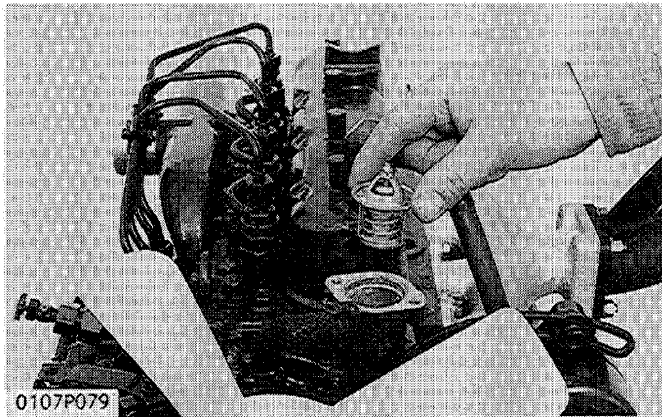

0107P079

Thermostat

1. Remove the thermostat cover.
2. Remove the thermostat.

(When reassembling)

- Apply a liquid gasket (Three Bond 1215 or equivalent) only at the thermostat cover side of the gasket.

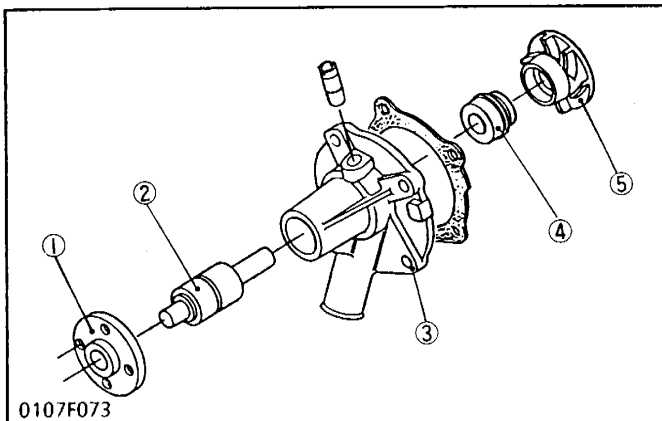

0107F073

Water Pump

1. Remove the fan and fan pulley.
2. Remove the water pump from gear case cover.
3. Remove the water pump flange (1).
4. Press out the water pump shaft (2) with the impeller (5) on it.
5. Remove the impeller from the water pump shaft.
6. Remove the mechanical seal (4).

(When reassembling)

- Replace the mechanical seal with new one.

- (1) Water Pump Flange
- (2) Water Pump Shaft
- (3) Water Pump Body
- (4) Mechanical Seal
- (5) Impeller

4 FU

CHECKI

[1] INJEC

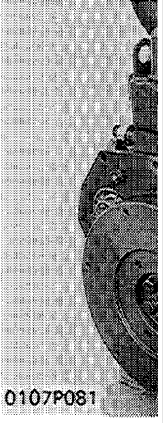

0107P081

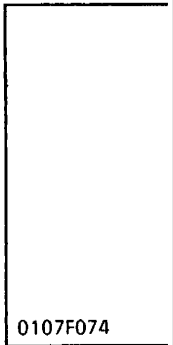

0107F074

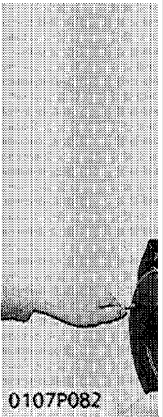

0107P082

[2] INJECTION NOZZLE

⚠ CAUTION

- Check the nozzle injection pressure and condition after confirming that there is nobody standing in the direction the fume goes. If the fume from the nozzle directly contacts the human body, cells may be destroyed and blood poisoning may be caused.

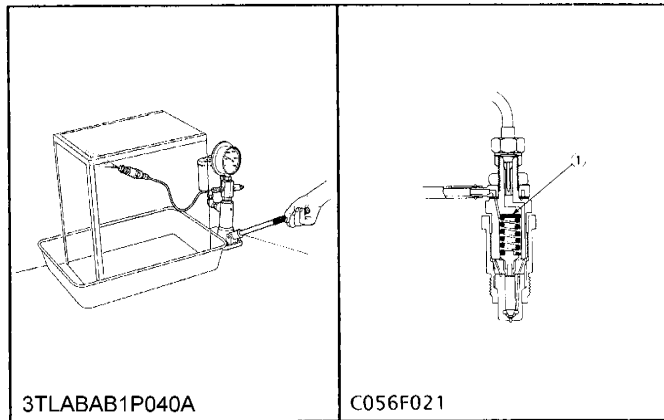

Nozzle Injection Pressure

1. Set the injection nozzle to the nozzle tester.
2. Slowly move the tester handle to measure the pressure at which fuel begins jetting out from the nozzle.
3. If the measurement is not within the factory specifications, disassemble the injection nozzle, and change adjusting washer (1) until the proper injection pressure is obtained.

(Reference)

- Pressure variation with 0.1 mm (0.004 in.) difference of adjusting washer thickness.
Approx. 981 kPa (10 kgf/cm², 142 psi)

(1) Adjusting Washer

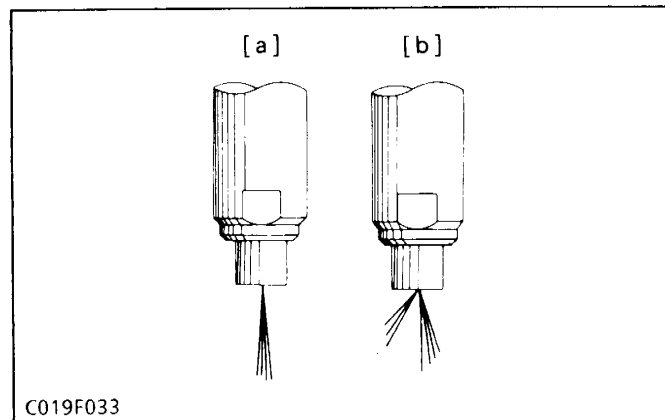

Nozzle Spraying Condition

1. Set the injection nozzle to a nozzle tester and check the nozzle spraying condition.
2. If the spraying condition is defective, replace the nozzle piece.

[a] Good

[b] Bad

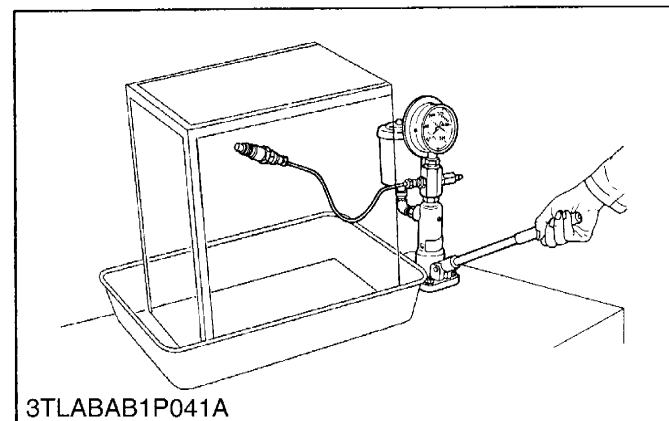

Fuel Tightness of Needle Valve Seat

1. Set the injection nozzle to a nozzle tester.
Apply a pressure 12.75 MPa (130kgf/cm², 1849 psi).
2. After keeping the nozzle under this pressure for 10 seconds, check to see if fuel leaks from the nozzle.
3. If fuel should leak, replace the nozzle piece.

DISASSEMBLING AND ASSEMBLING

[1] INJECTION PUMP

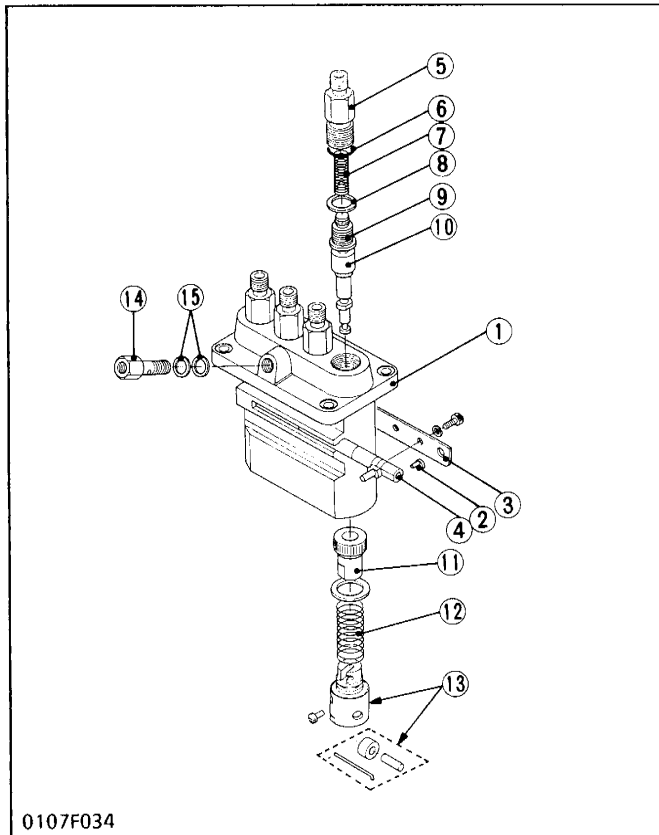

■ IMPORTANT

- If replacing the pump element, the amount of fuel injection should be adjusted on a specified bench.

- (1) Pump Body
- (2) Adjust Plate
- (3) Plate
- (4) Control Rack
- (5) Delivery Valve Holder
- (6) O-ring
- (7) Delivery Valve Spring
- (8) Gasket
- (9) Delivery Valve
- (10) Pump Element
- (11) Control Sleeve
- (12) Plunger Spring
- (13) Tappet
- (14) Hollow Screw
- (15) Gasket

[2] INJECTION NOZZLE

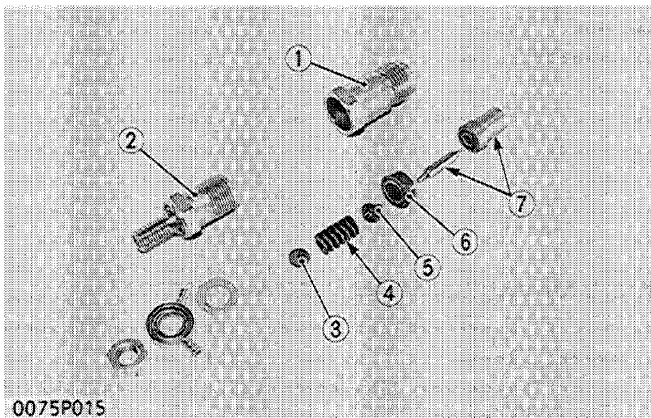

Nozzle Holder

1. Secure the nozzle retaining nut (1) with a vise.
2. Remove the nozzle holder (2), and take out parts inside.

(When reassembling)

- Assemble the nozzle in clean fuel oil.
- Install the push rod (5), noting its direction.
- After assembling the nozzle, be sure to adjust the fuel injection pressure.

- (1) Nozzle Retaining Nut
- (2) Nozzle Holder
- (3) Adjusting Washer
- (4) Nozzle Spring
- (5) Push Rod
- (6) Distance Piece
- (7) Nozzle Piece

5 ELECTRICAL SYSTEM

CHECKING

[1] ALTERNATOR AND REGULATOR

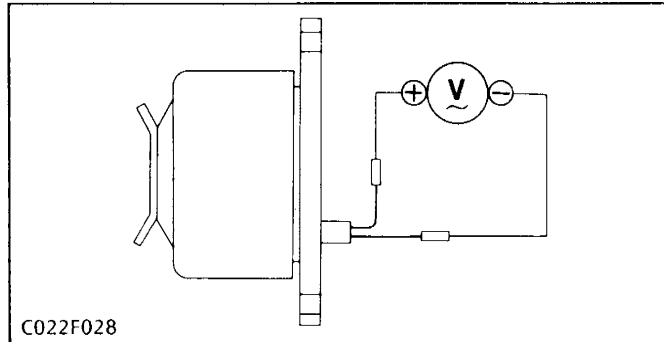

C022F028

Alternator's No-load Voltage

1. Disconnect the lead wire from the alternator.
2. Start the engine and measure the voltage generated by the alternator.

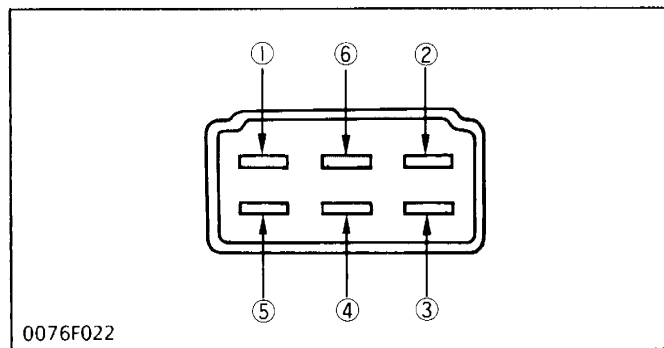

0076F022

Continuity across Regulator's Terminals

1. Remove the regulator coupler.
2. Check with a tester whether the regulator is in optimum condition or not.

NOTE

- Try to use a high-resistance tester as far as possible.
- The judgment should be as below table.
"ON" if the indicator moves, otherwise "OFF".

Check Table

		Cord colors					
		blue	blue	red	yellow	green	black
Cord colors	blue	OFF	ON	OFF	OFF	OFF	OFF
	blue	OFF	ON	OFF	OFF	OFF	OFF
	red	OFF	OFF	ON	OFF	OFF	OFF
	yellow	ON	ON	ON	OFF	OFF	ON
	green	OFF	OFF	OFF	OFF	OFF	OFF
	black	OFF	OFF	OFF	OFF	OFF	OFF

- (1) Blue
- (2) Blue
- (3) Red
- (4) Yellow
- (5) Green
- (6) Black

[2] STARTER

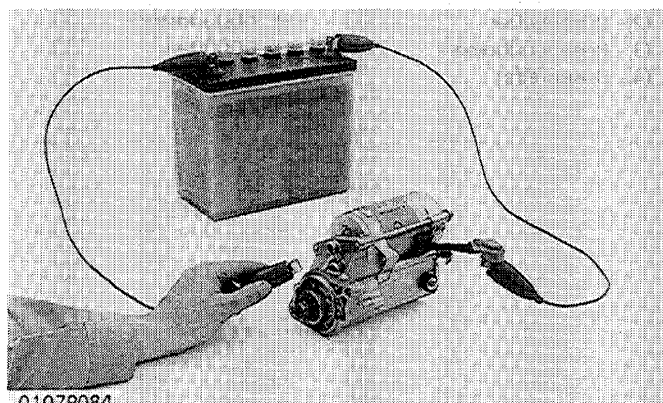

0107P084

Motor Test

1. Disconnect the connecting lead from the "C" terminal of the starter and connect a jumper lead from the connecting lead to the positive battery terminal.
2. Connect a jumper lead momentarily between the starter body and the negative battery terminal.
3. If the motor does not run, check the motor.

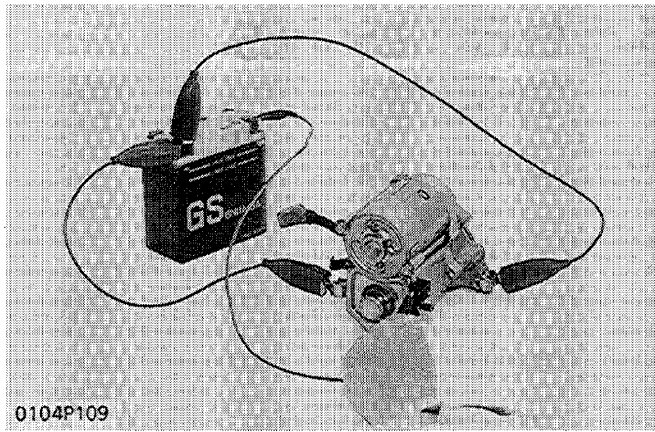

0104P109

Magnet Switch

1. Disconnect the connecting lead from the "C" terminal of the starter.
2. Connect jumper leads from the negative terminal of 6V battery to the body and "C" terminal of the magnet switch.
3. The pinion gear should pop out, when a jumper lead is connected between the positive terminal of the battery to the "S" terminal of the magnet switch.
4. The pinion gear should stay out without the jumper from the negative terminal to the "C" terminal.

■ NOTE

- Each test should be carried out for a short time, about 3 to 5 seconds.

[3] GLOW PLUG

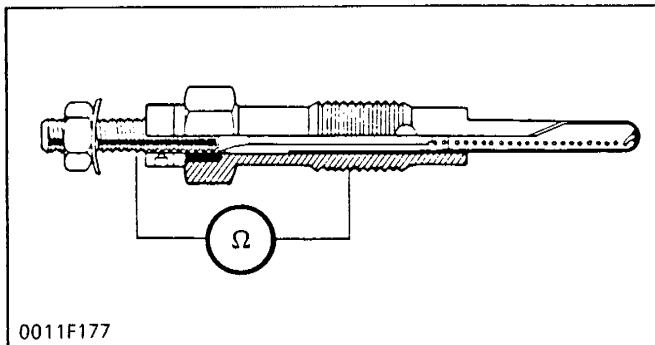

0011F177

Glow Plug

1. Disconnect the leads from the glow plugs.
2. Measure the resistance with an circuit tester across the glow plug terminal and the housing.
3. If 0 ohm is indicated, the screw at the tip of the glow plug and the housing are short-circuited. If the reference value is not indicated, the glow plug is faulty, replace the glow plug.

DISASSEMBLING AND ASSEMBLING

[1] STARTER

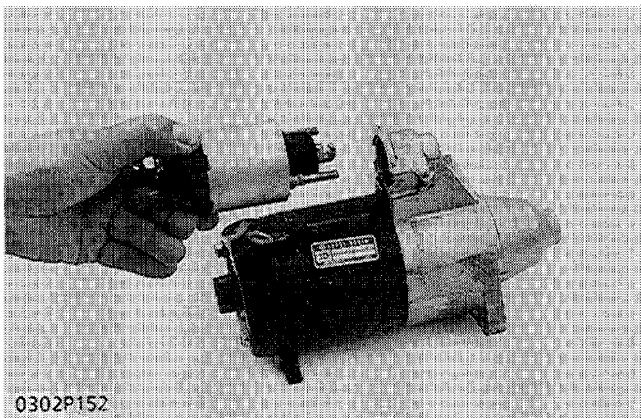

0302P152

Magnet Switch

1. Disconnect the connecting lead.
2. Remove the mounting nuts.
3. Remove the magnet switch by sliding it up so that it is disconnected from the drive lever.

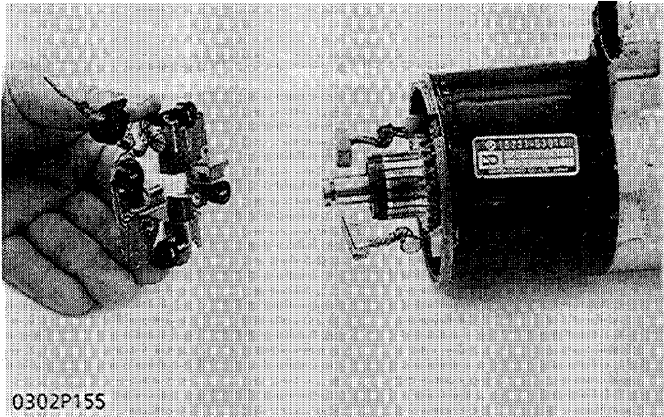
**Brush Holder**

1. Draw out the brush from the hold while holding the spring up.
2. Remove the brush holder.

(When reassembling)

- When replacing the spring, install it by referring to the figure.
- Do not contact the brush's positive lead with the body.

0302P155

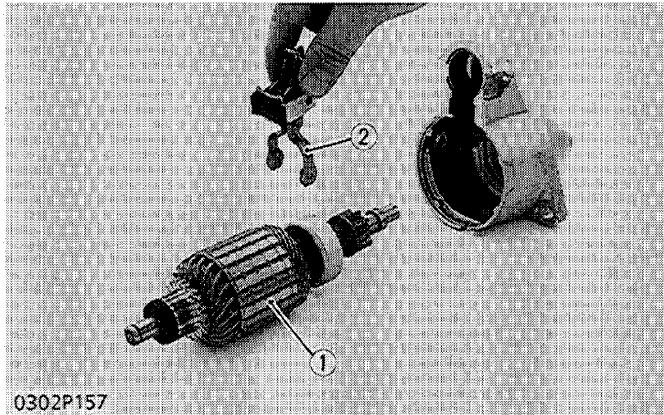
**Armature**

1. Draw out the armature (1) with the drive lever (2).

(When reassembling)

- Install the drive lever, nothing its direction.

- (1) Armature
(2) Drive Lever

0302P157

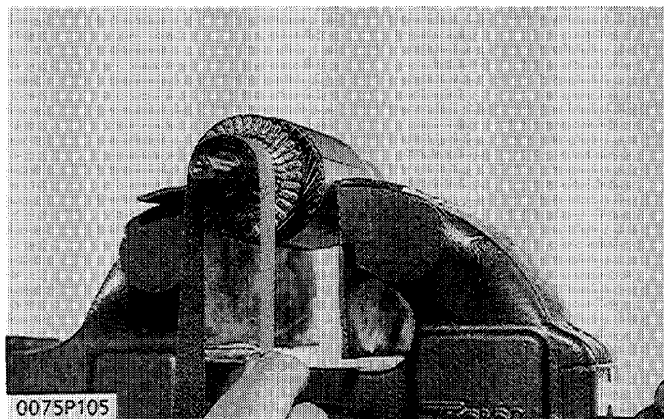
SERVICING**[1] STARTER****Commutator and Mica**

1. Check the contact face of the commutator for wear, and grind the commutator with sand paper if it is slightly worn.
2. Measure the commutator O.D. at several points.
3. If the difference of the O.D.'s exceeds the allowable limit, correct the commutator on a lathe to the factory specification.
4. If the minimum O.D. is less than the allowable limit, replace the armature.
5. Measure the mica undercut.
6. If the undercut is less than the allowable limit, correct with a saw blade and chamfer the segment edges.

- [a] Bad
[b] Good

- (1) Mica
(2) Segment
(3) Depth of Mica

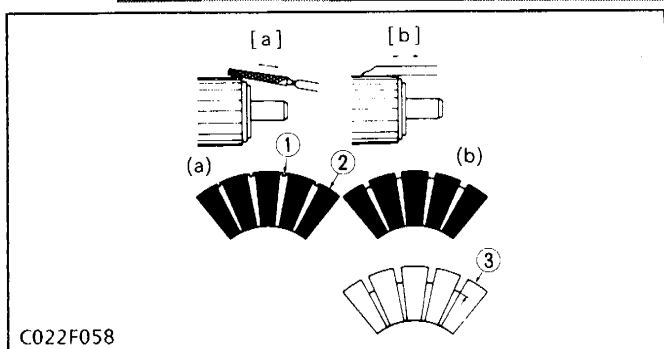

C022F058

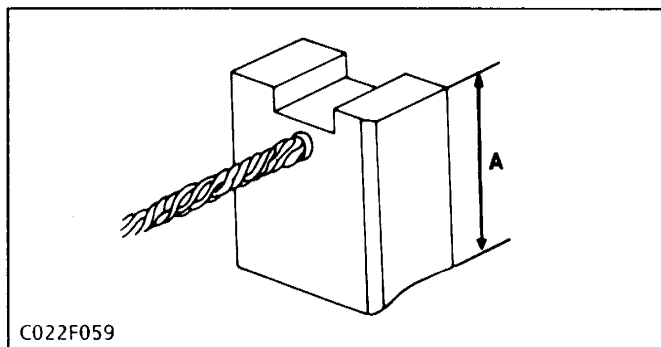

Brush Wear

1. Measure the brush length A.
2. If the length is less than the allowable limit, replace the brush.

EDITOR:

KUBOTA FARM & INDUSTRIAL MACHINERY SERVICE, LTD.

64, ISHIZU-KITAMACHI, SAKAI-KU, SAKAI-CITY, OSAKA, 590-0823, JAPAN

PHONE : (81)72-241-1129

FAX : (81)72-245-2484

E-mail : ksos-pub@kubota.co.jp
